

# Tessera Roll+

Basic Version + ⚡ E-KIT

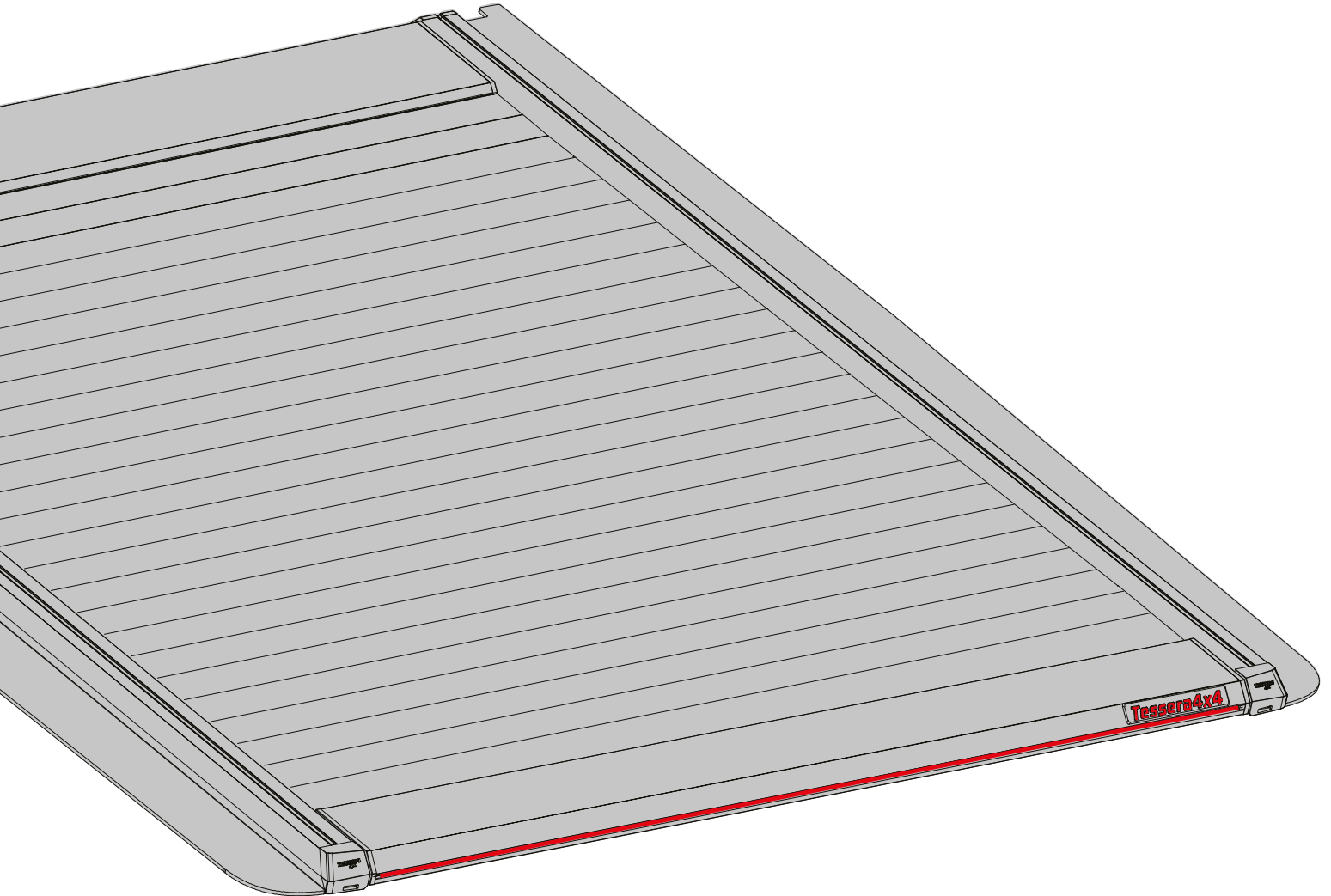

## Installation Manual

<b>PART NUMBER(S)</b>	<b>Model Year</b>
<b>TESS 1454 ROLL+E-KIT</b>	<b>KGM MUSSO EV</b>
<b>Cab(s)</b>	<b>Installation Time / Weight</b>
<b>Double Cab &amp; Space cab</b>	<b>90-120 minutes / 53-57 kg</b>



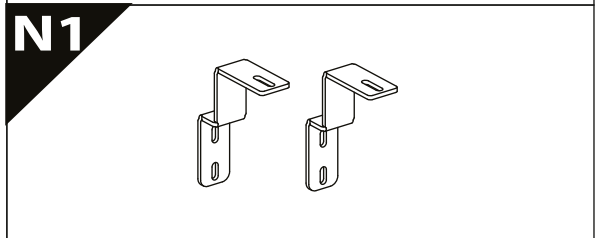
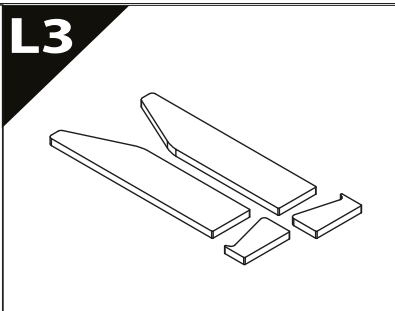
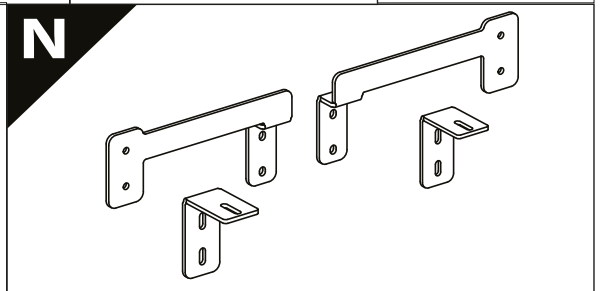
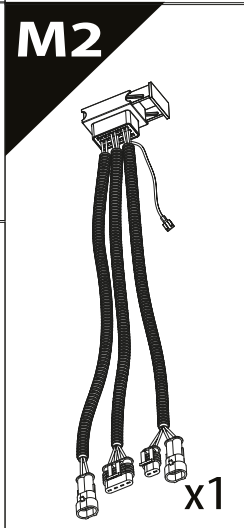
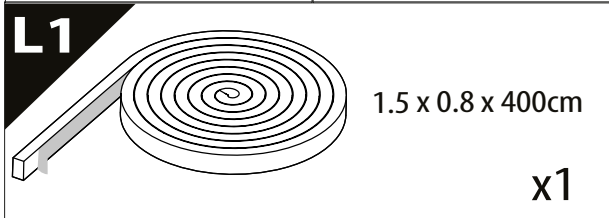
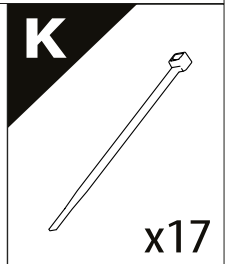
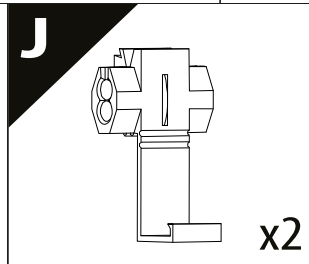
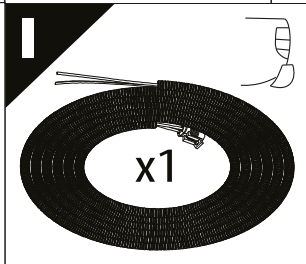
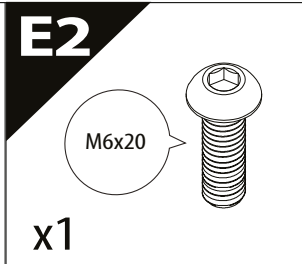
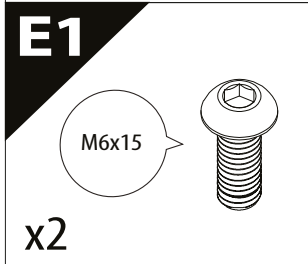
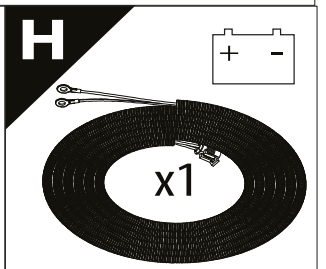
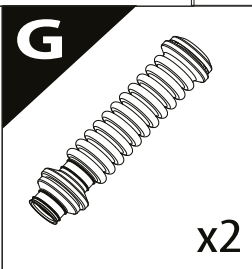
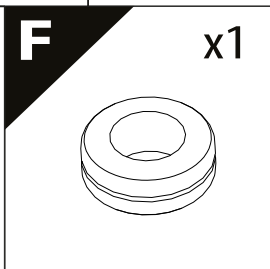
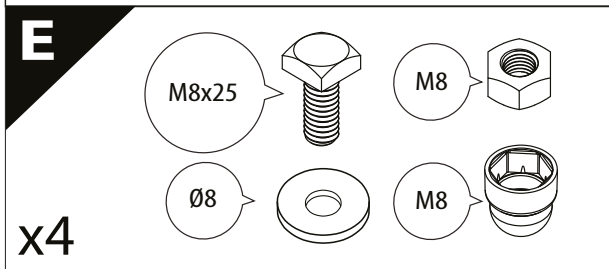
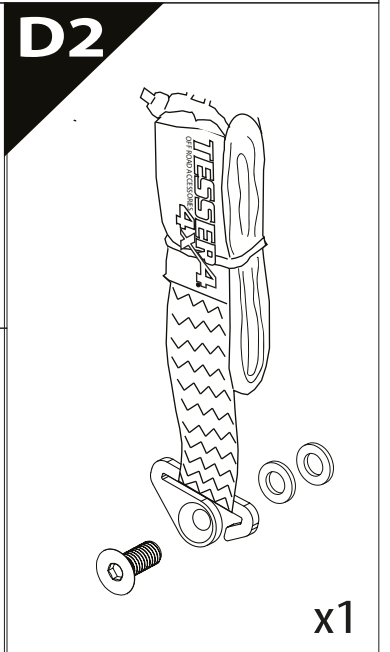
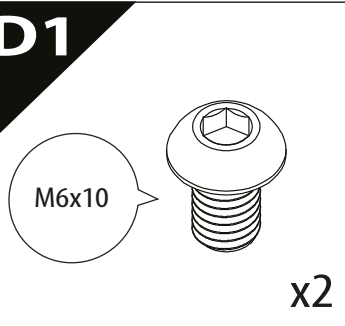
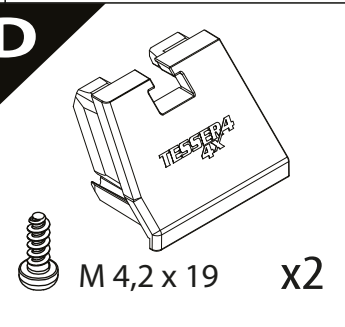
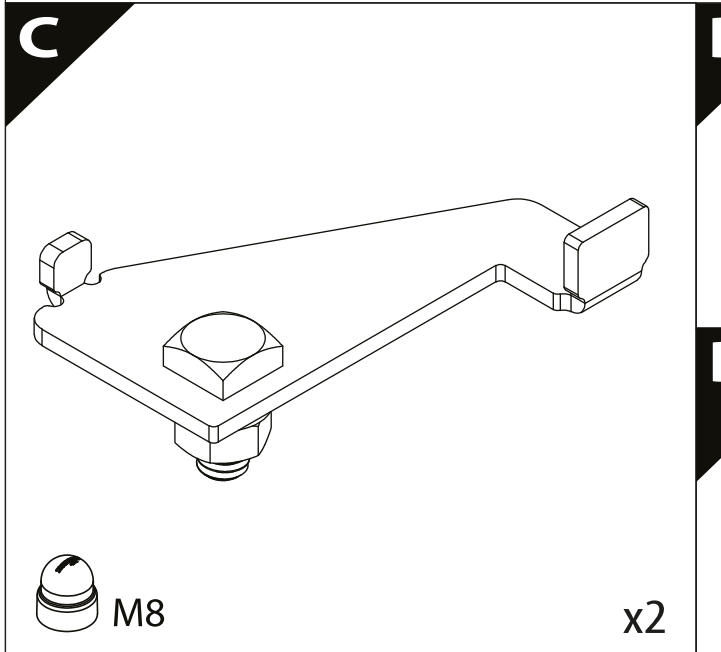
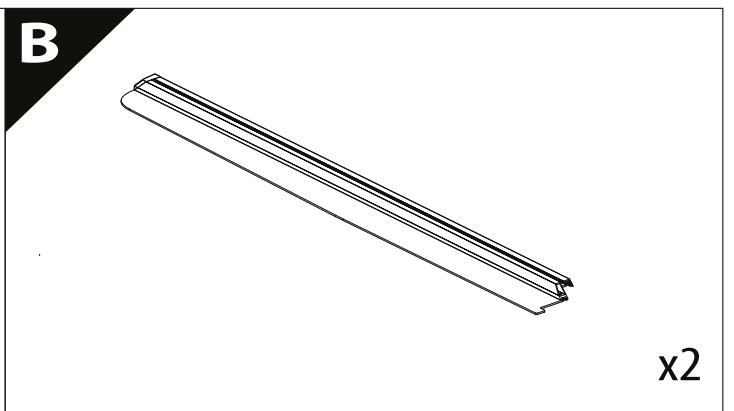
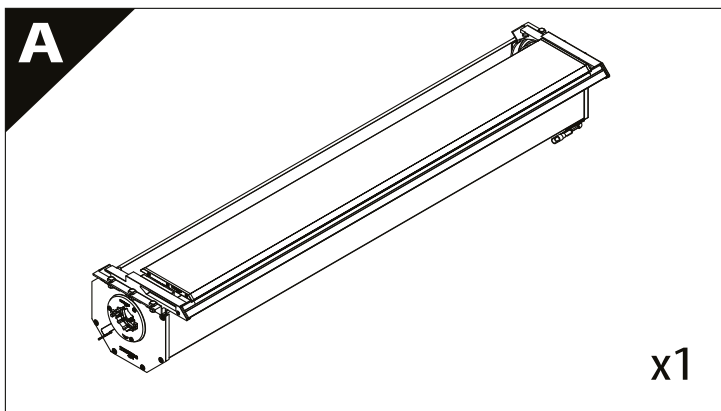

O

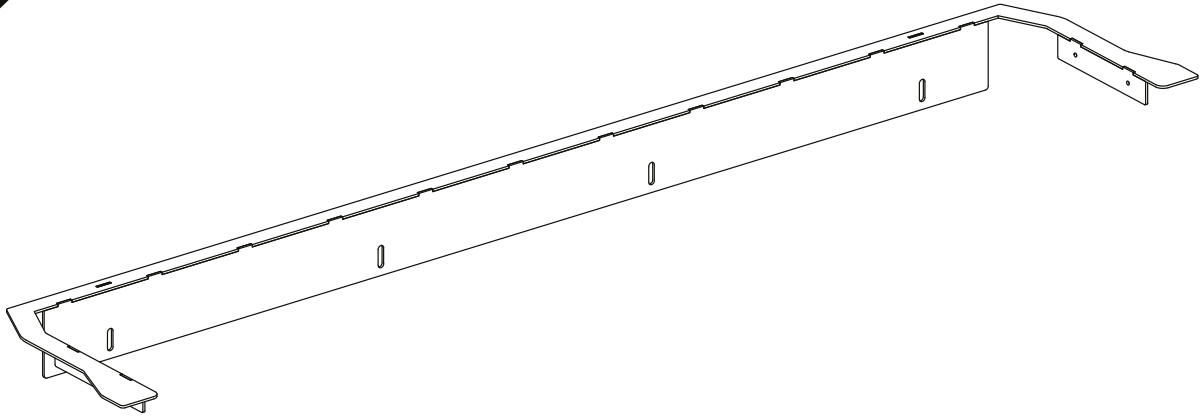

x1

P

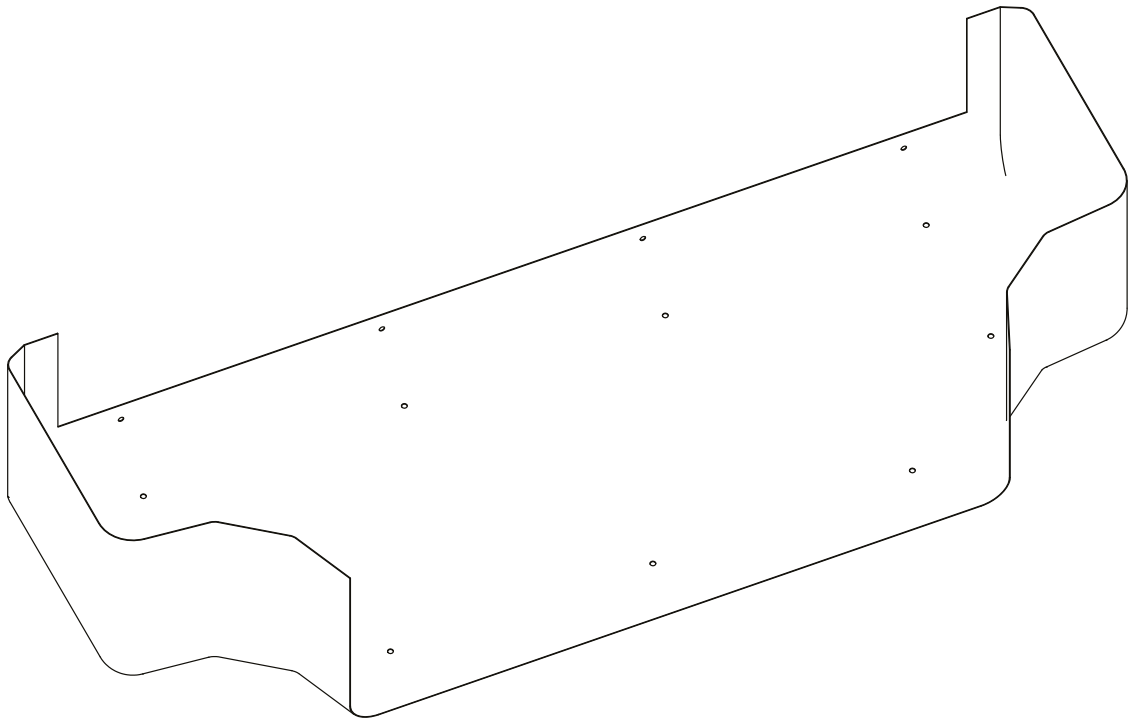

x1

Q

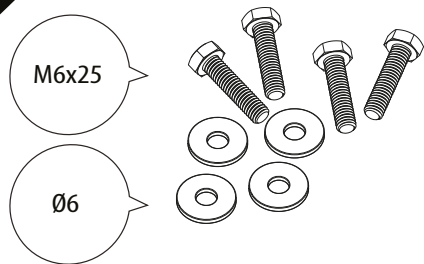

R

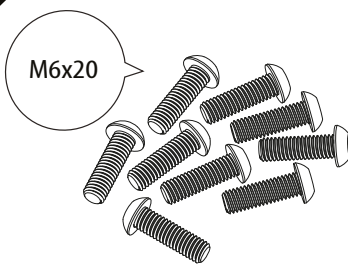

S

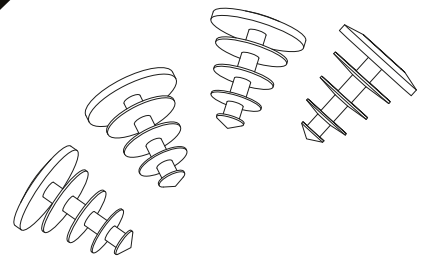

T

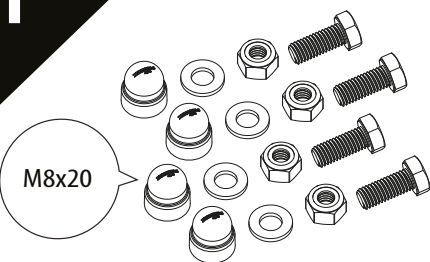

U

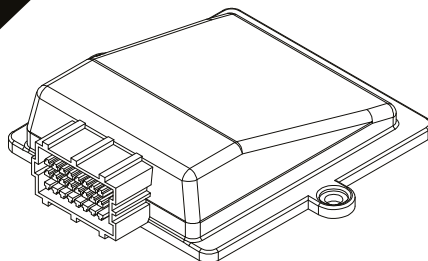

V

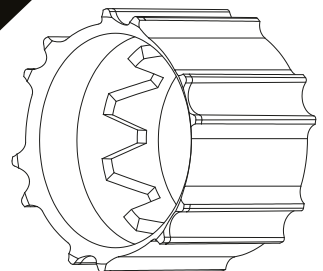

x1

**W**

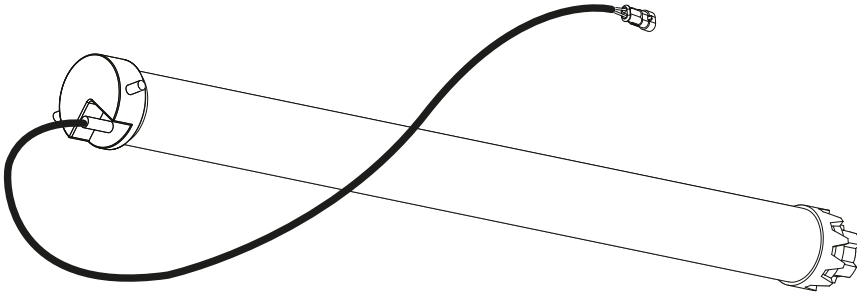

x1

**X**

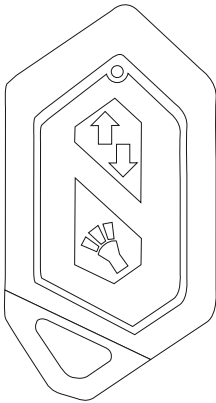

x2

**Y**



x2

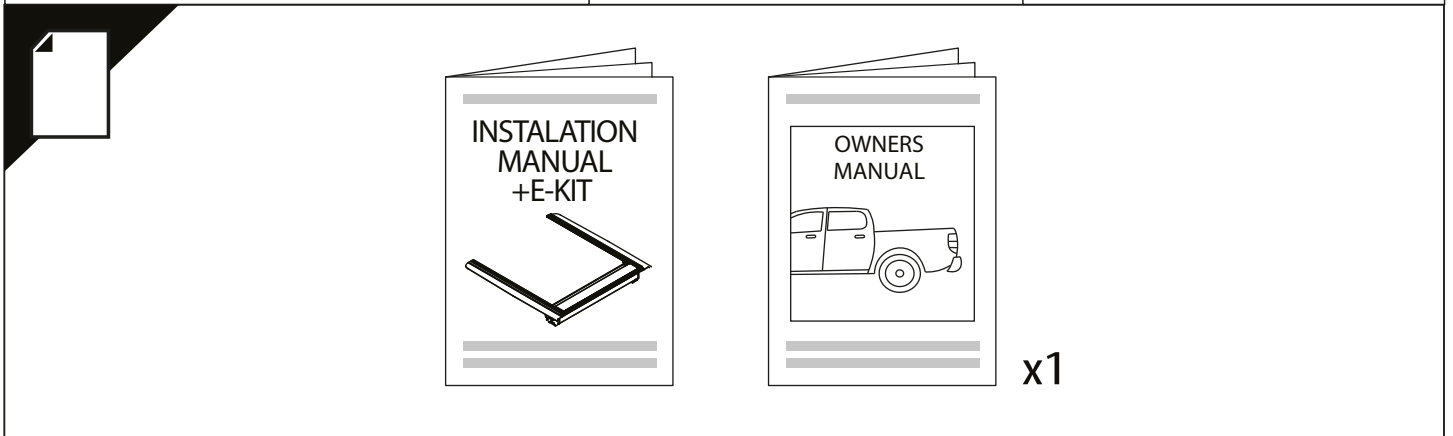
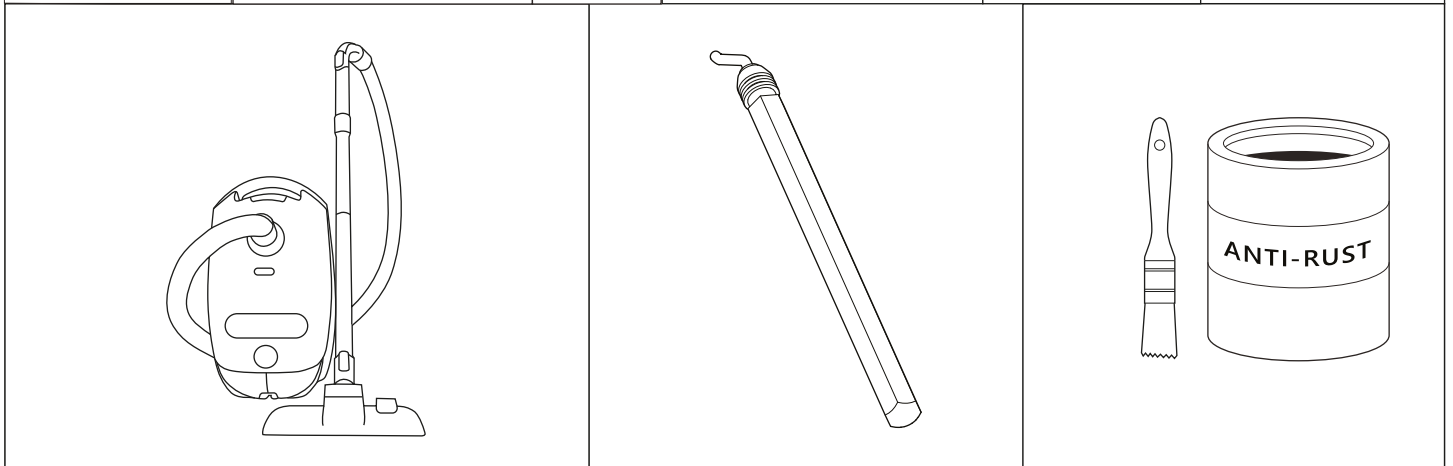
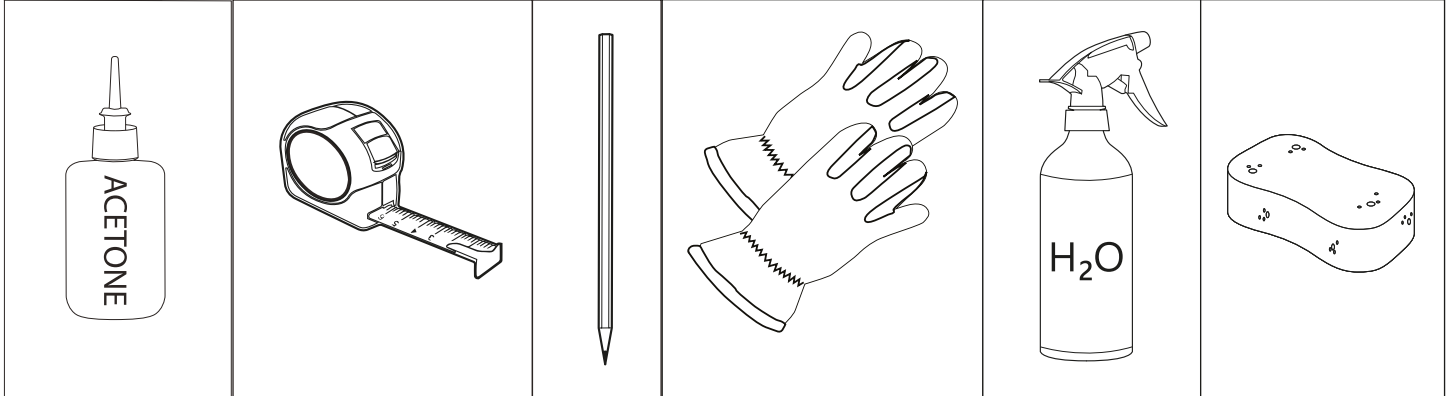
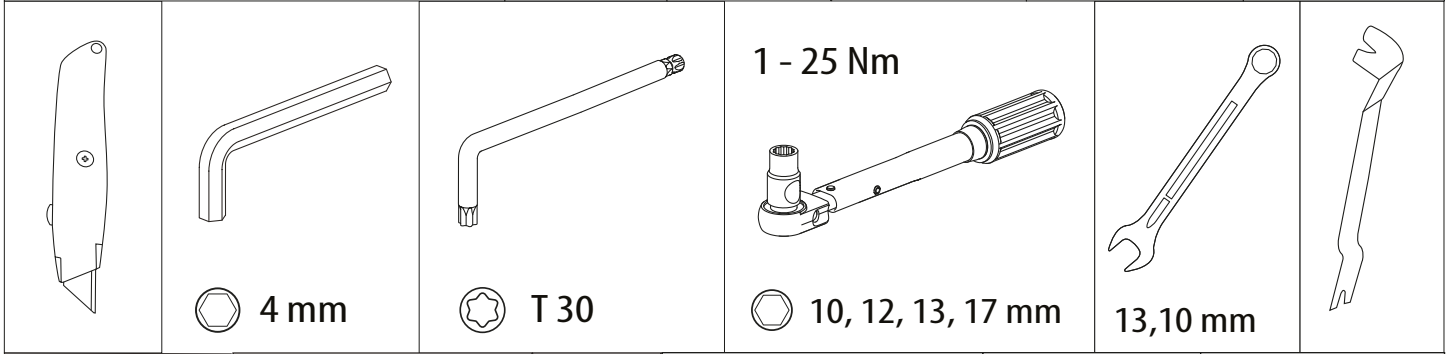
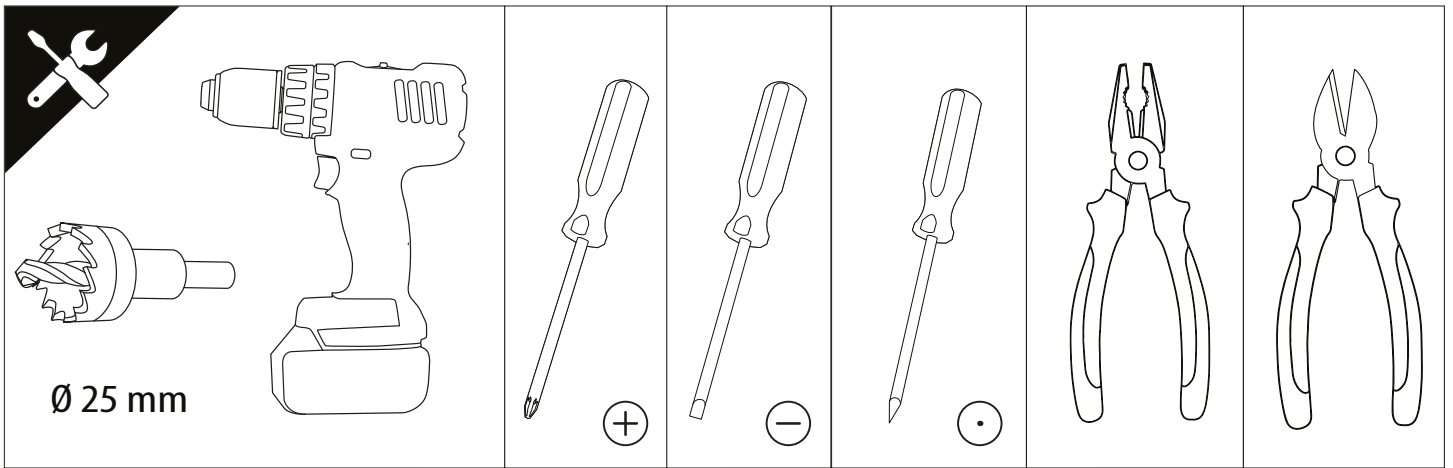

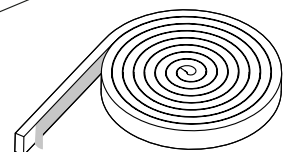
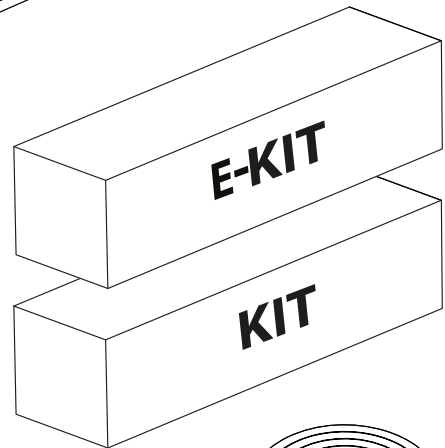
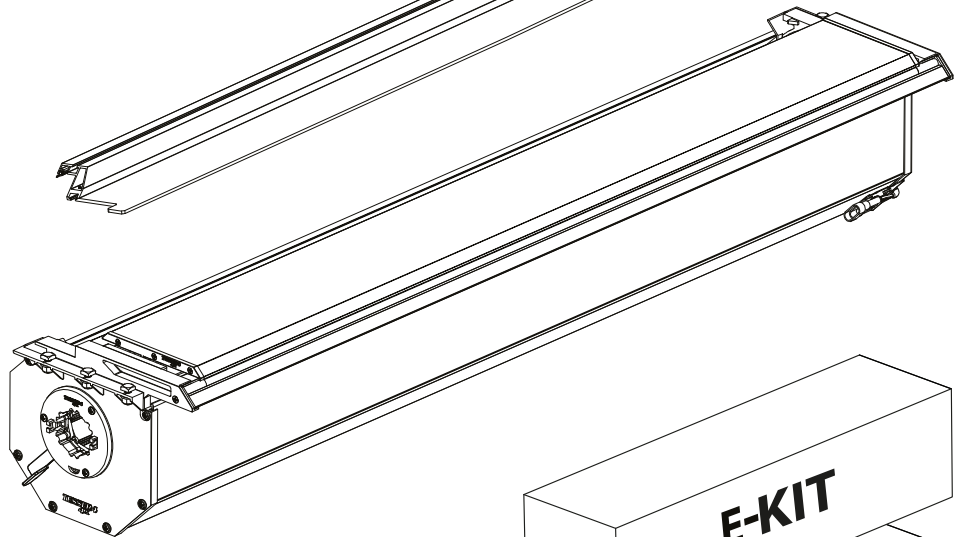
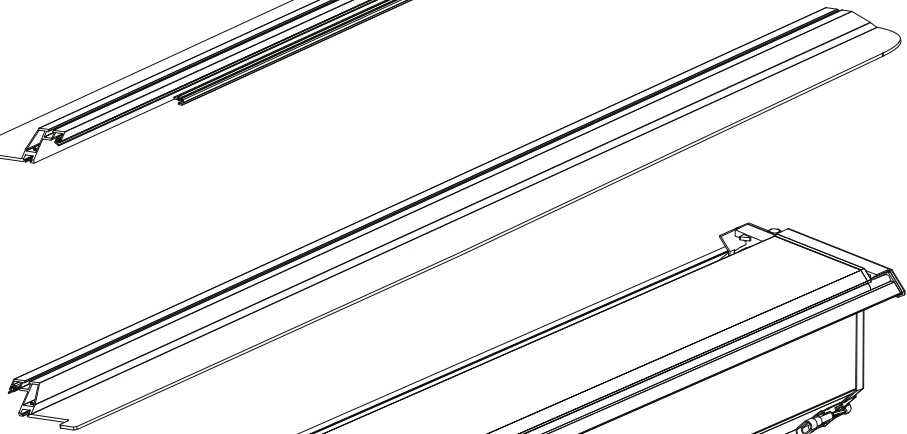
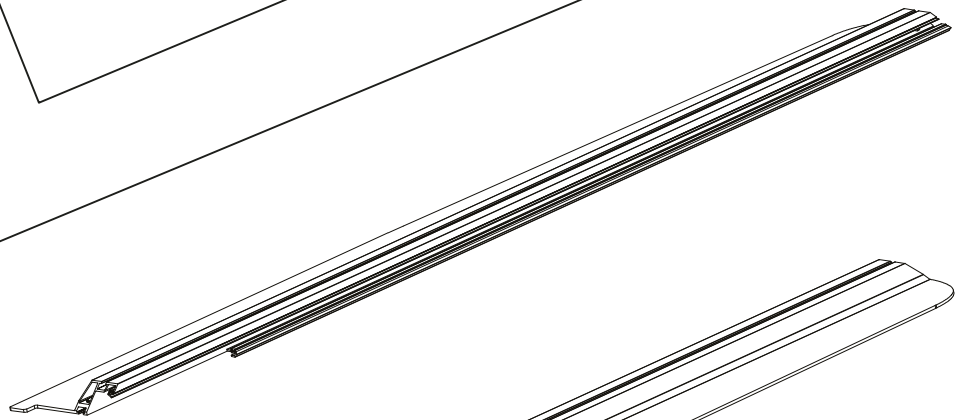
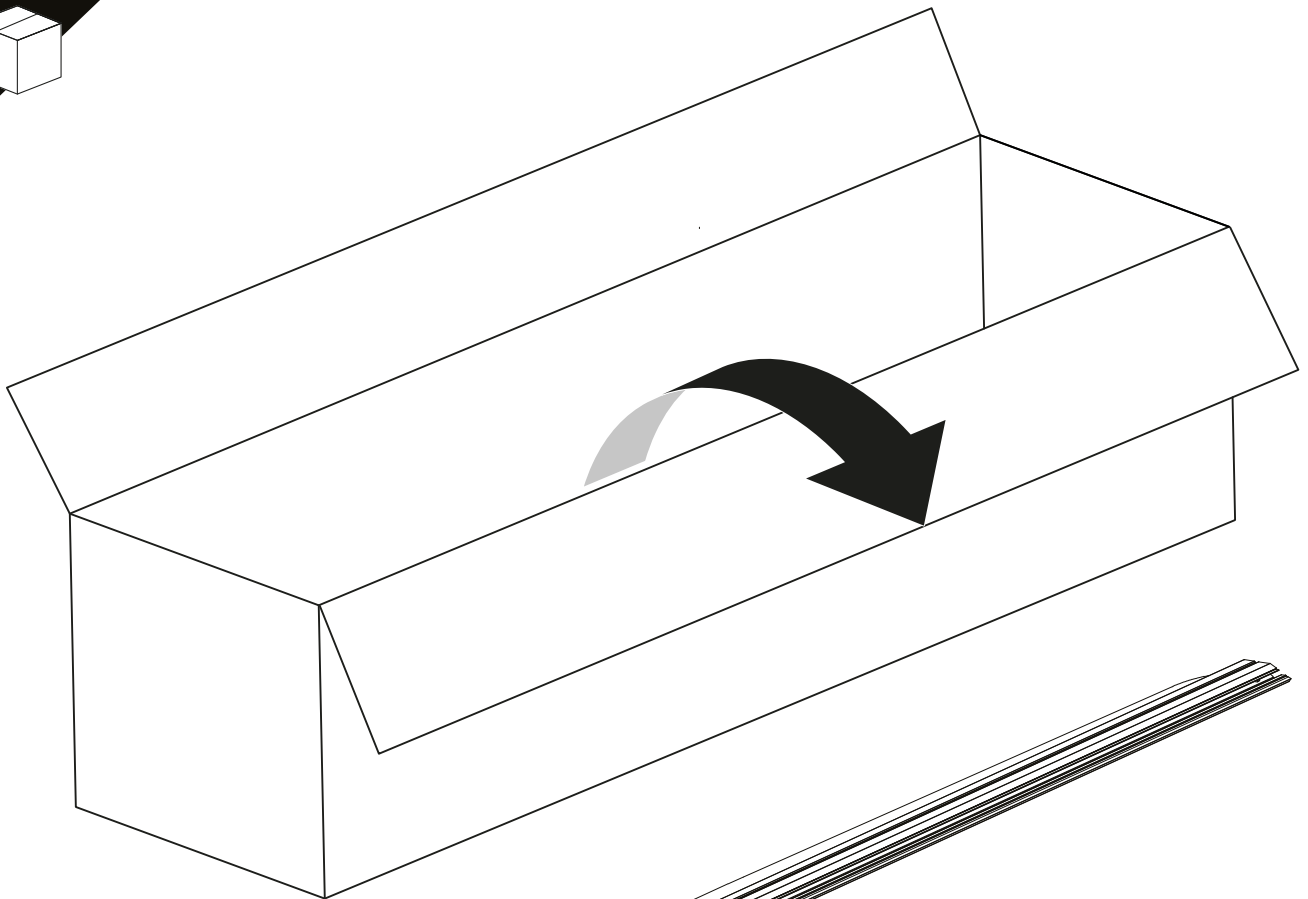

**B**

**A**

**KITS**

**L**

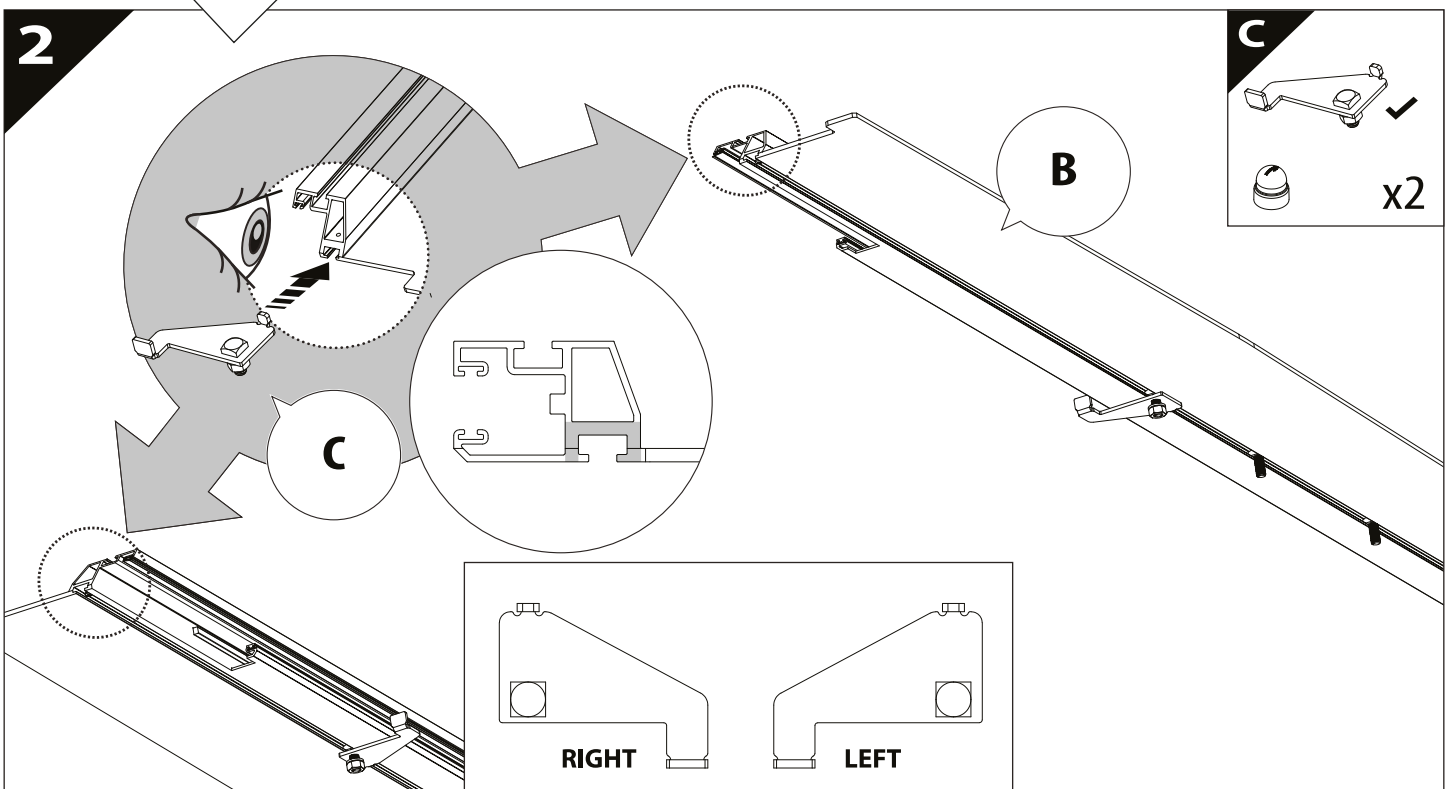
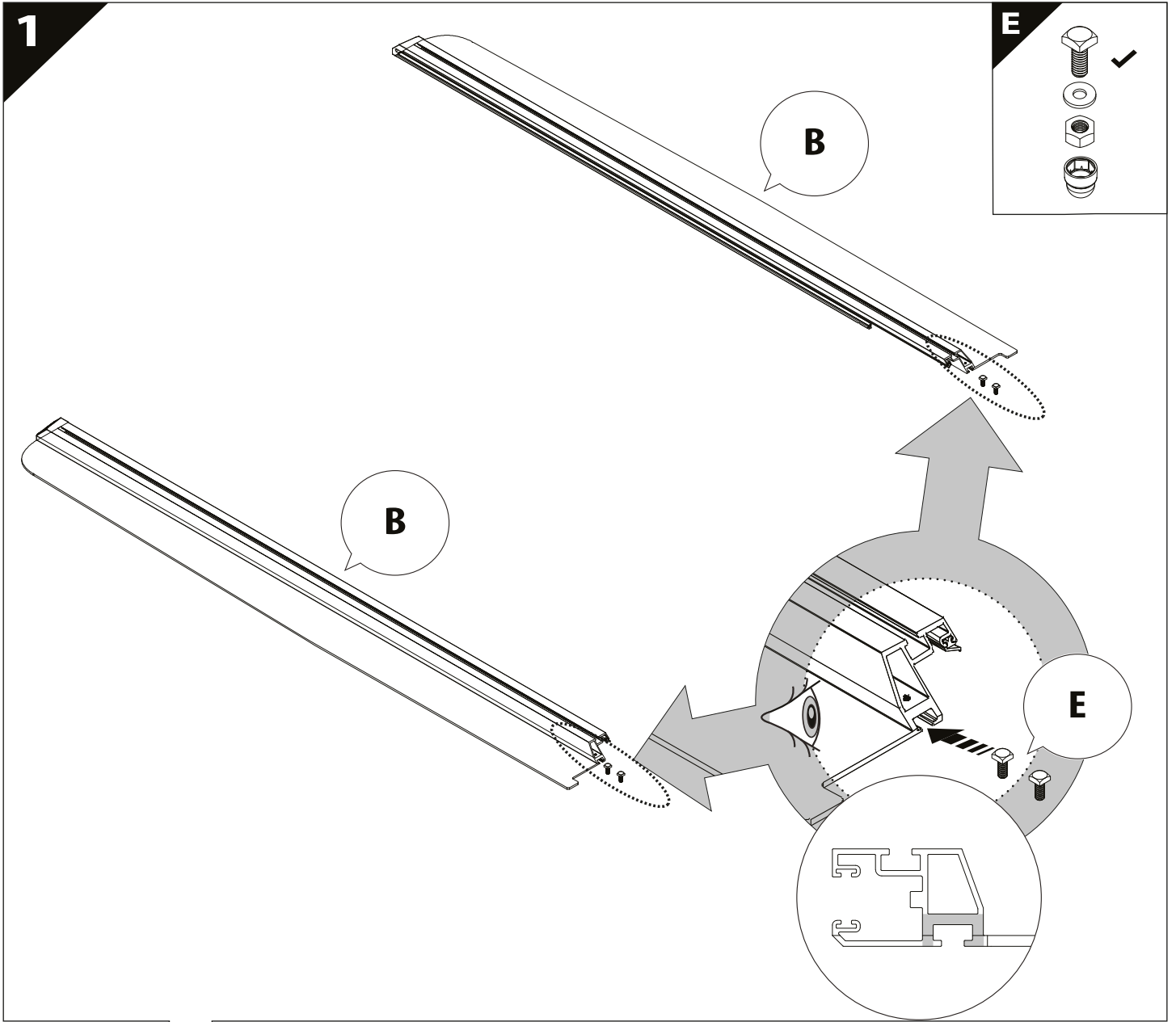

3

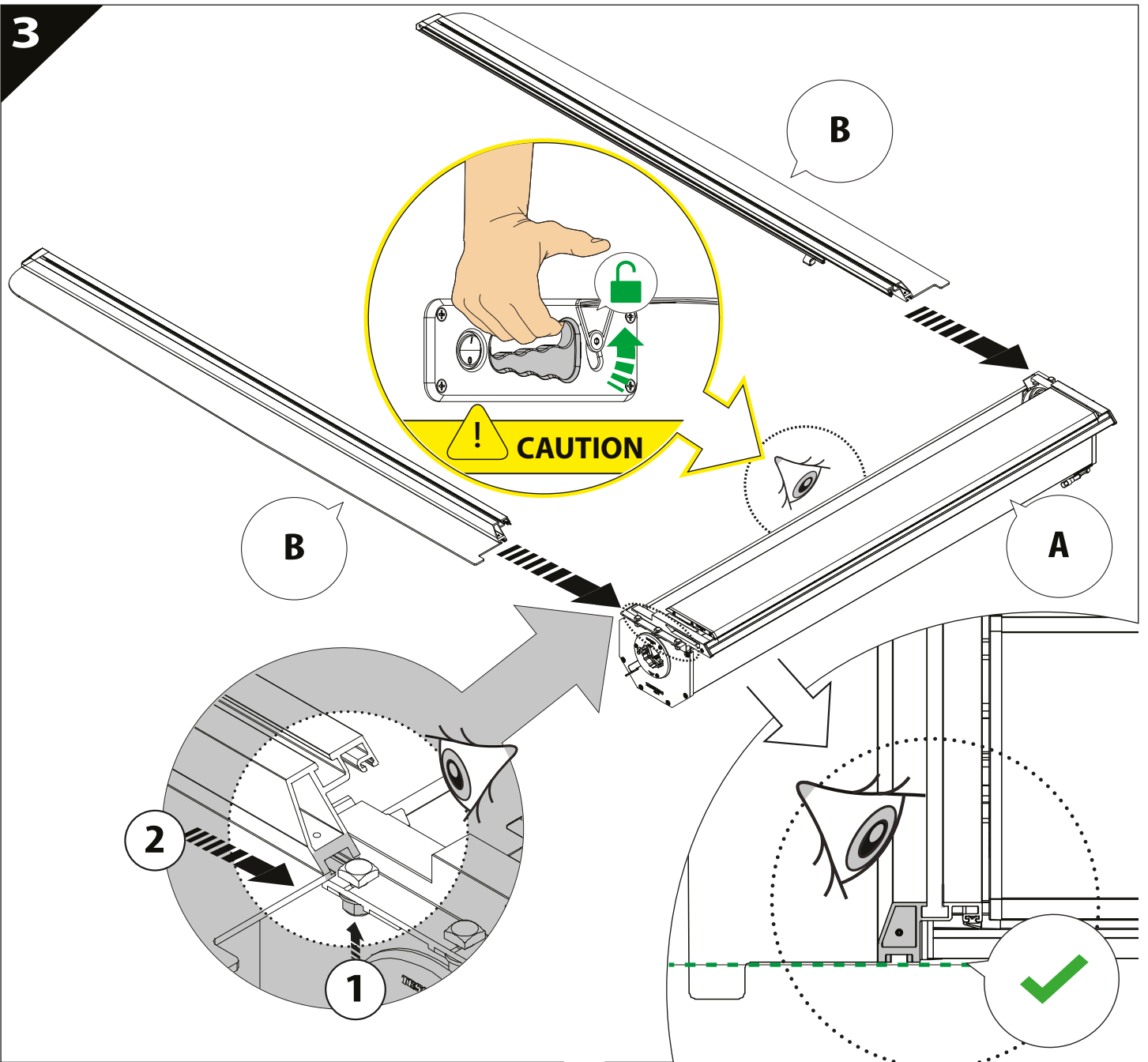

4

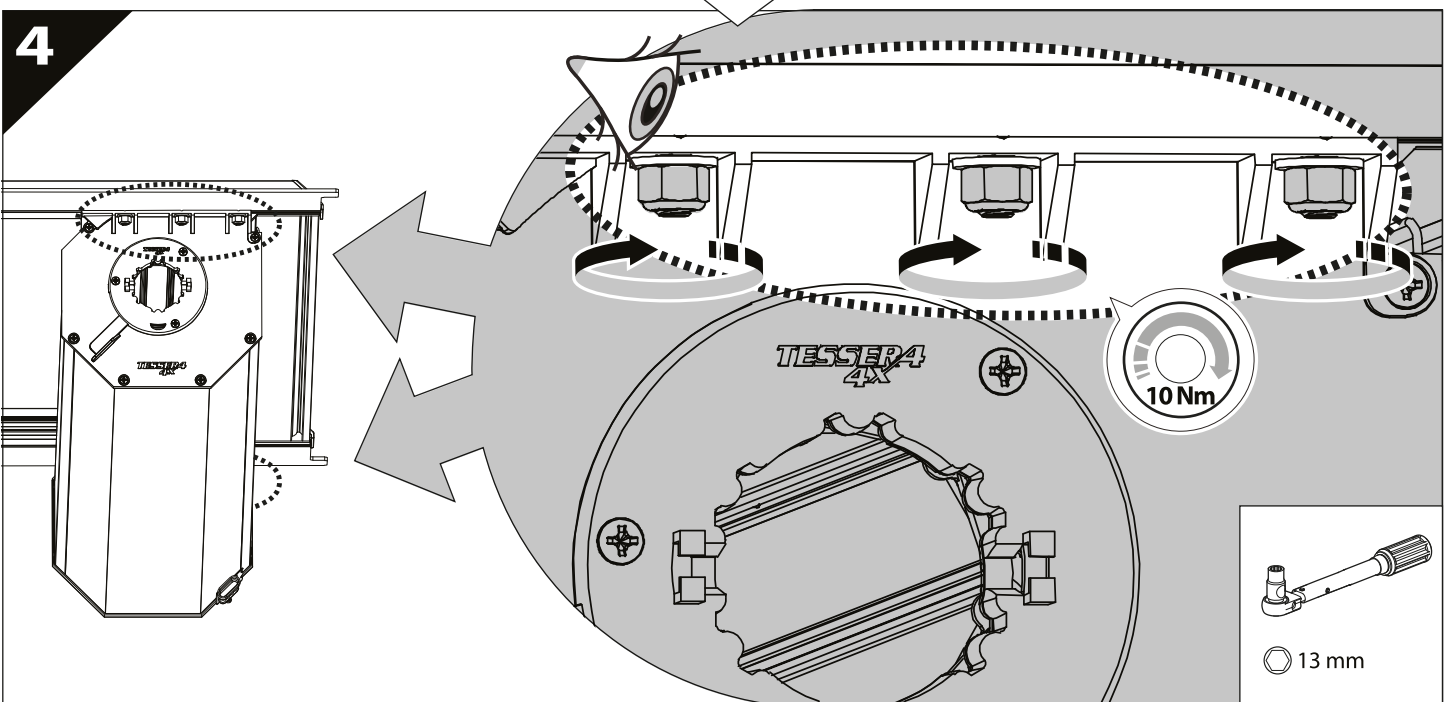

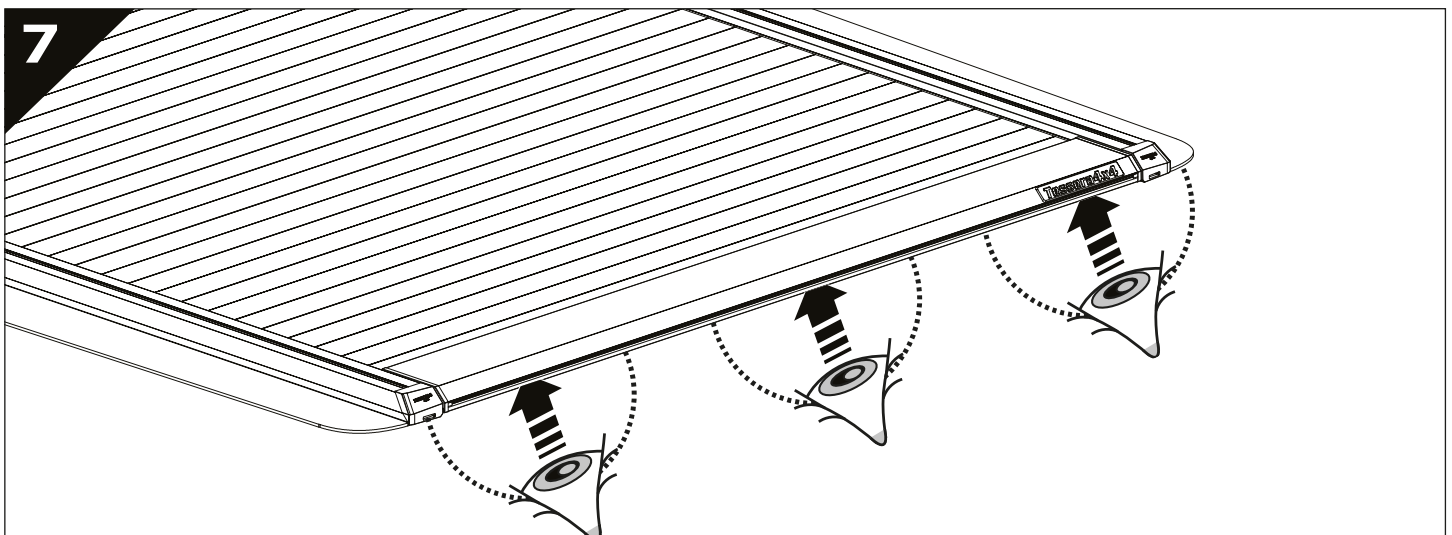
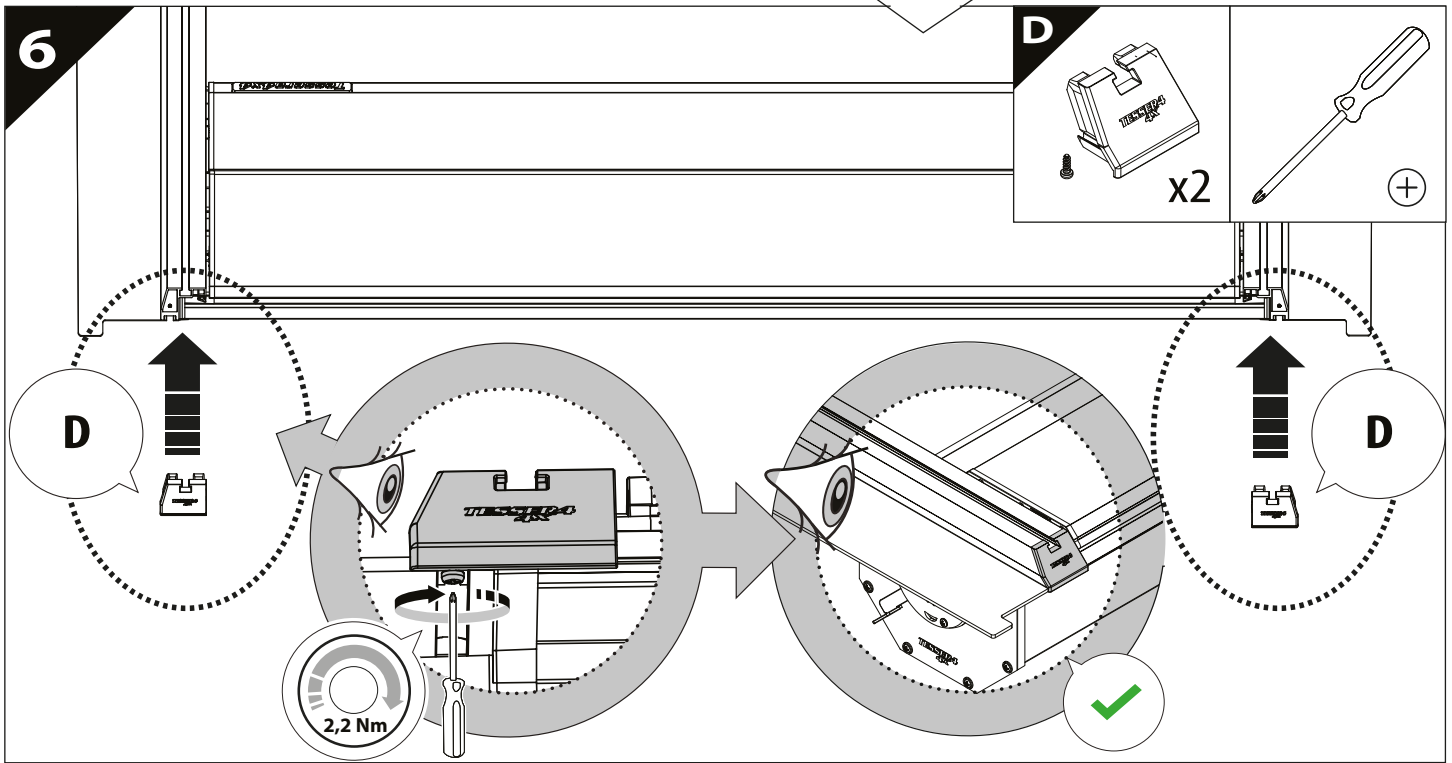
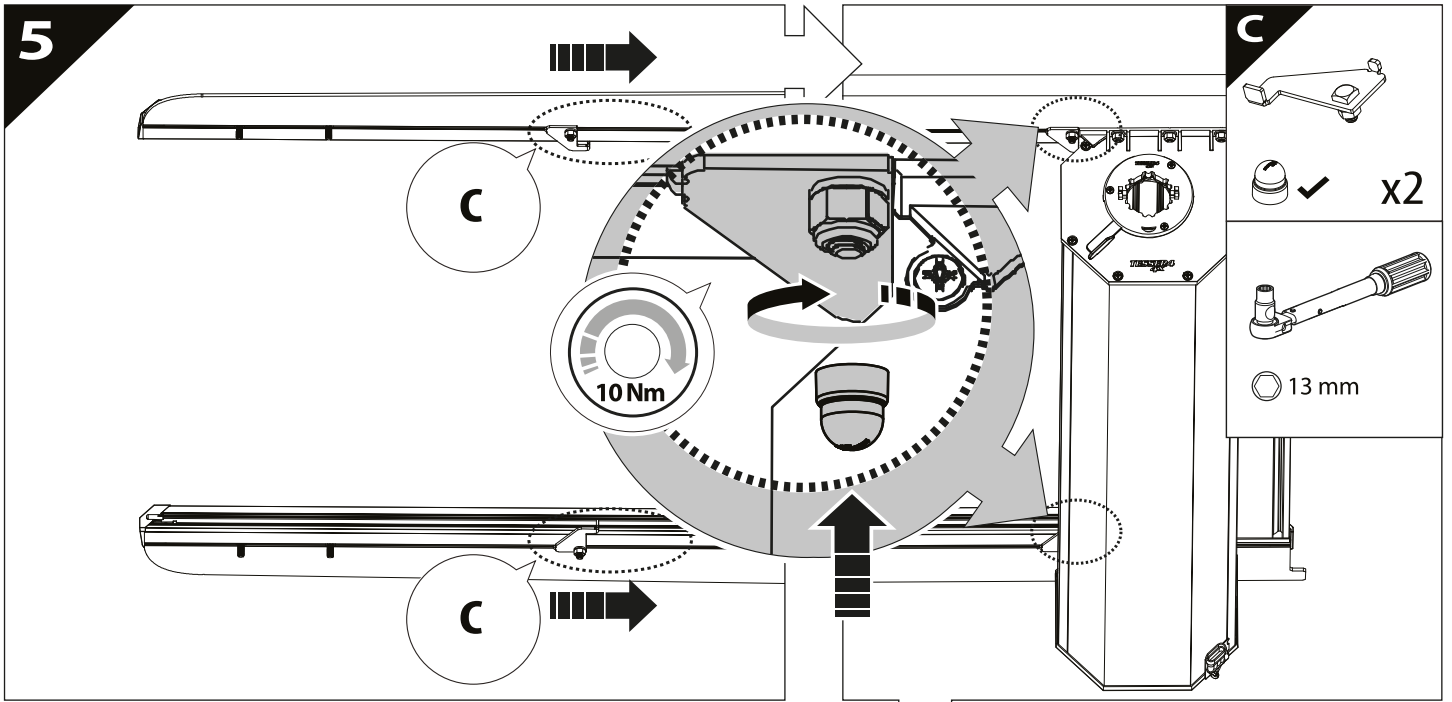

8

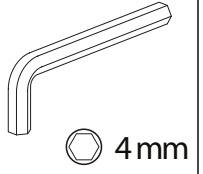
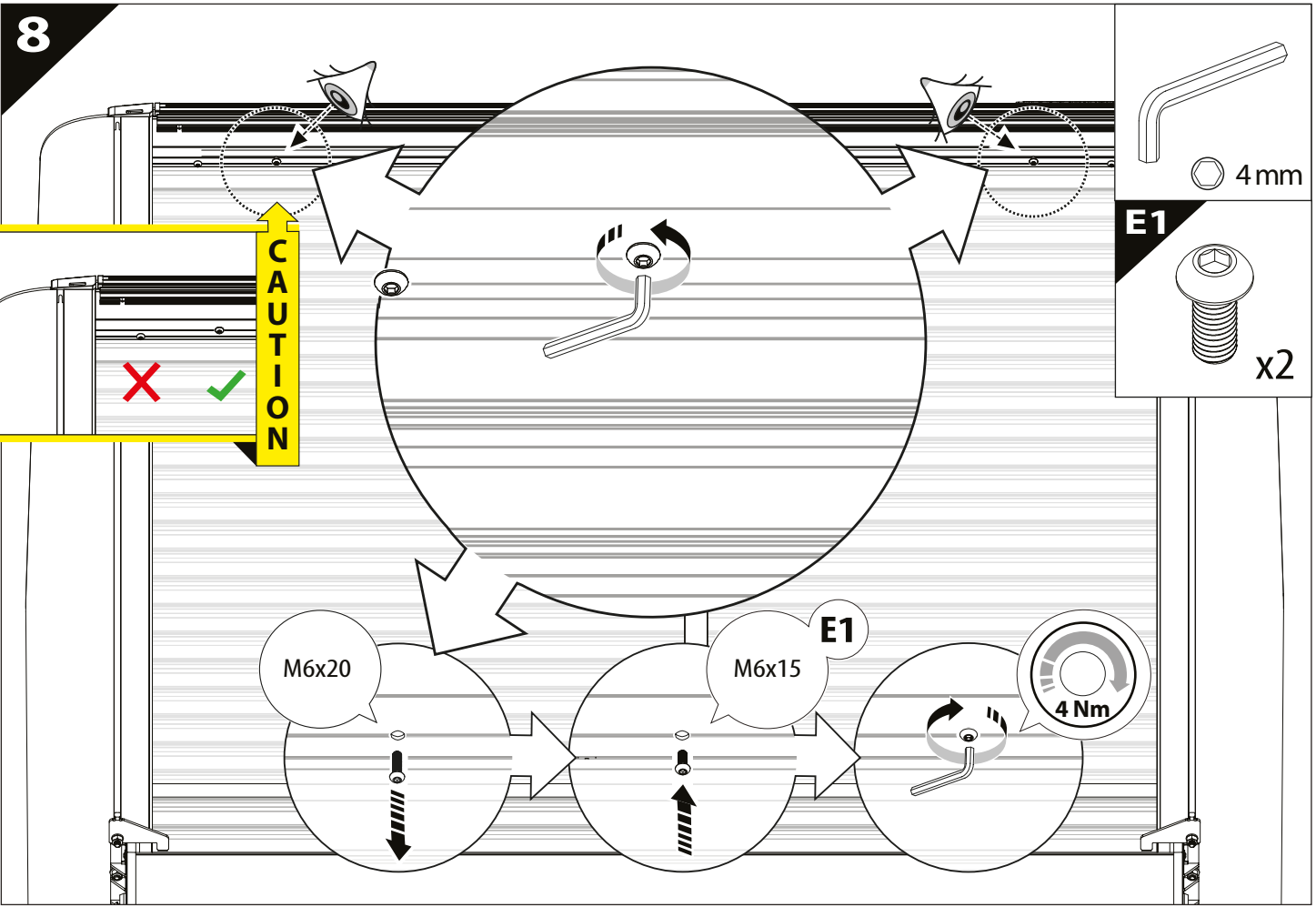
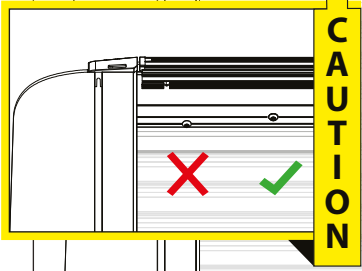

M6x20

M6x15

**E1**

4 Nm

9

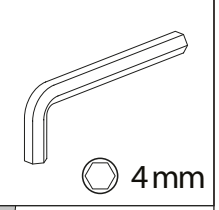
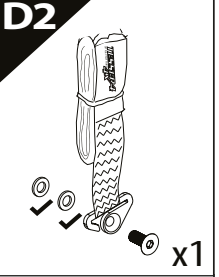
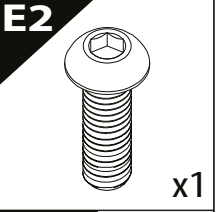
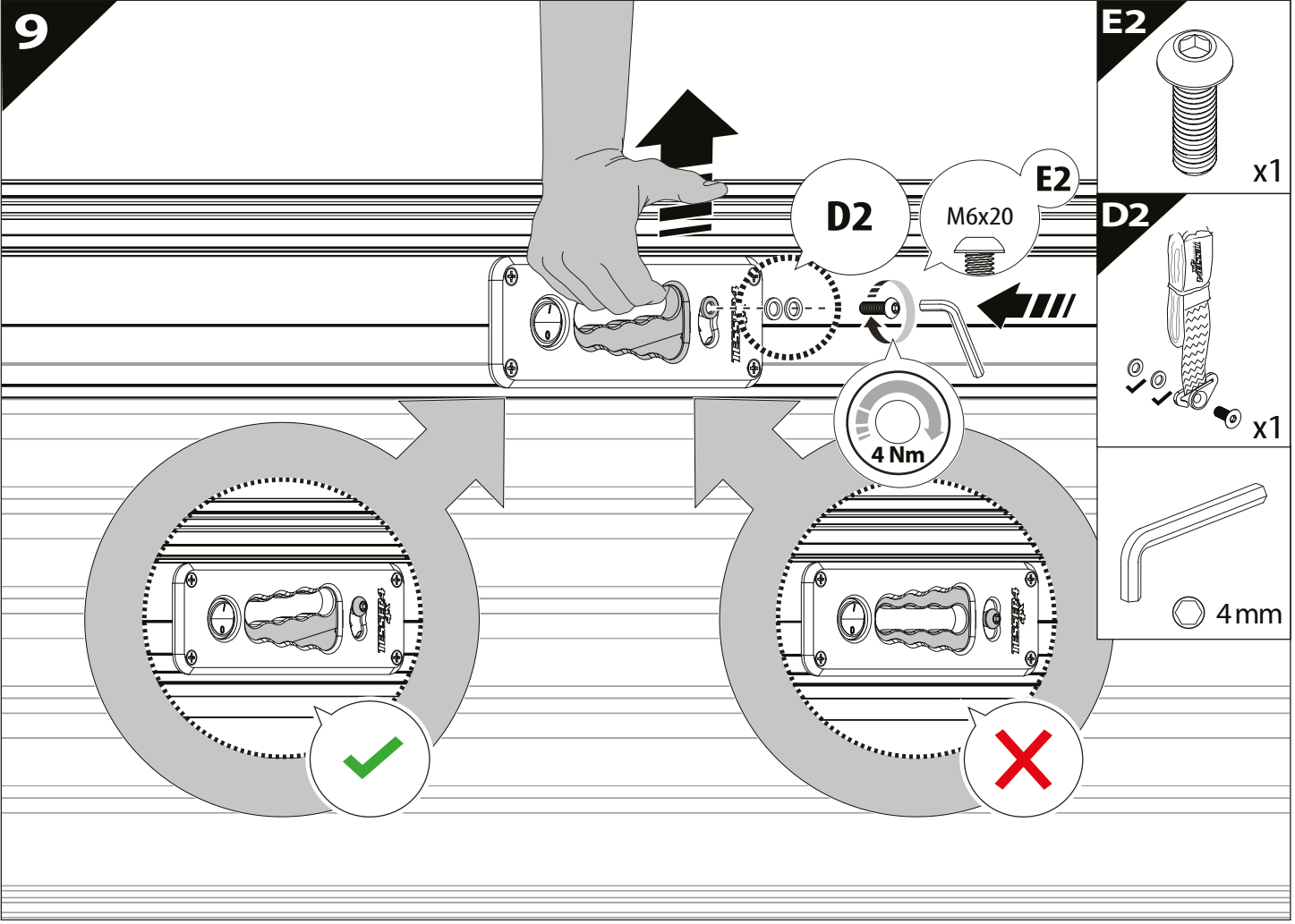

**D2**

M6x20

**E2**

4 Nm



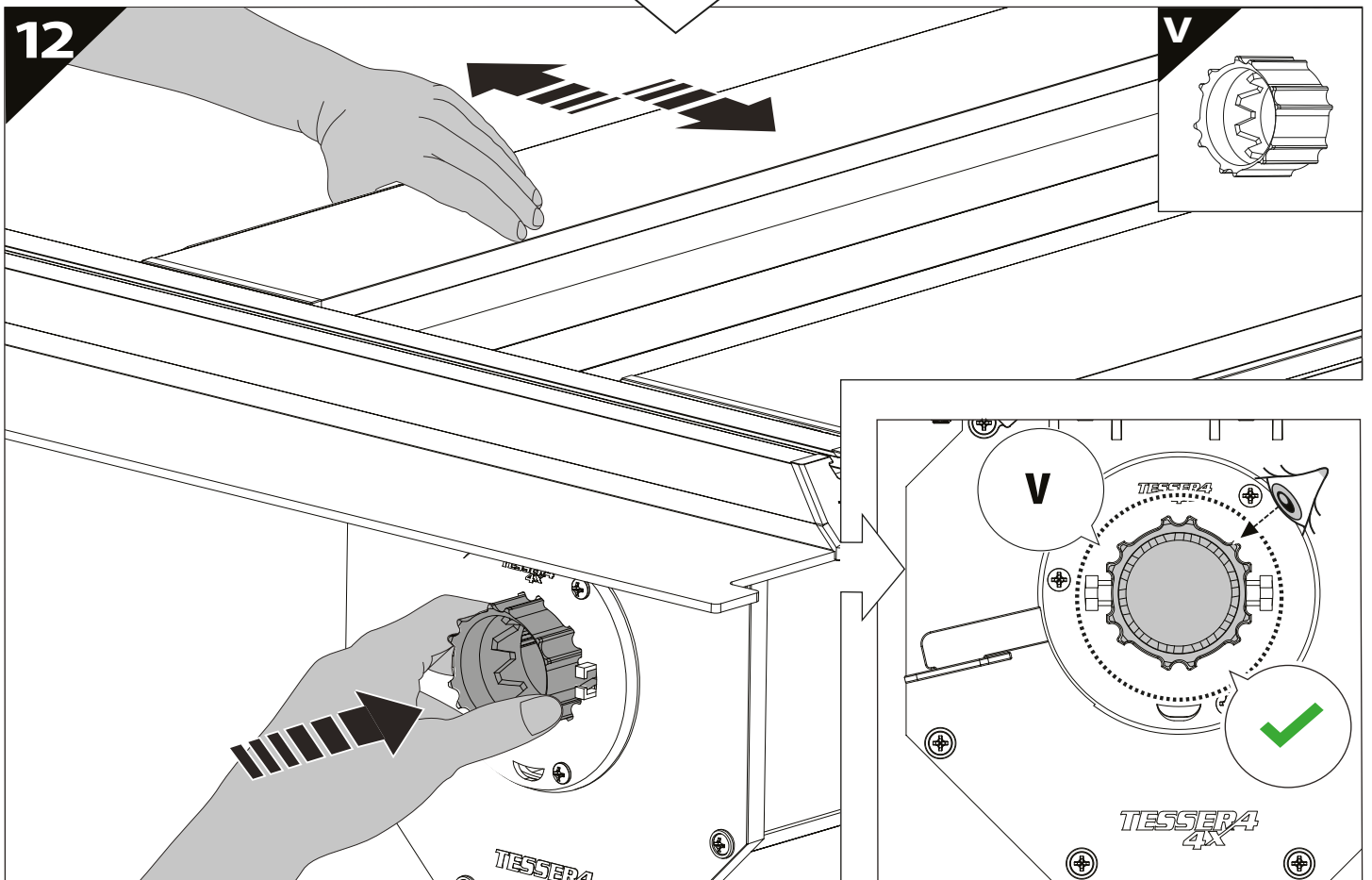
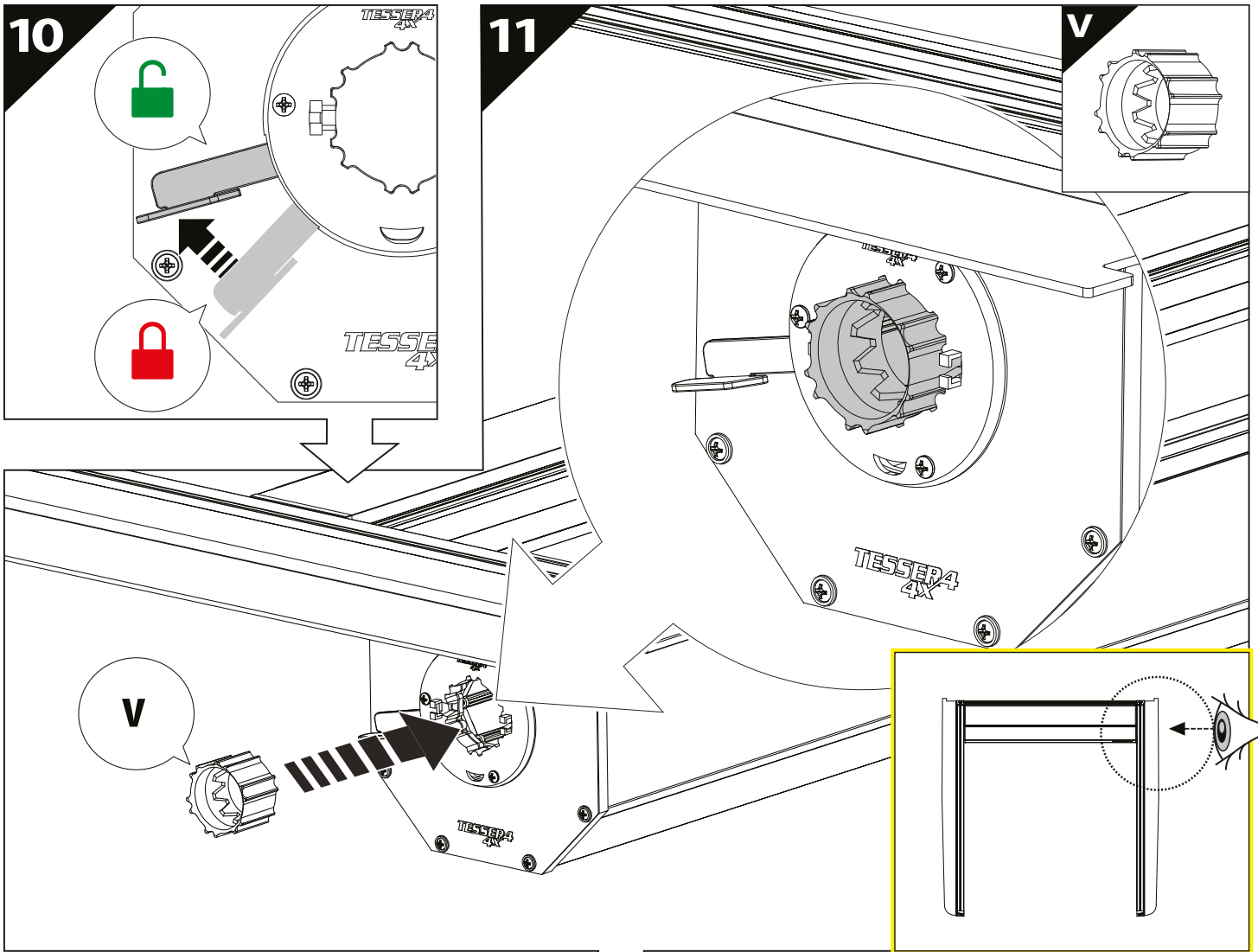

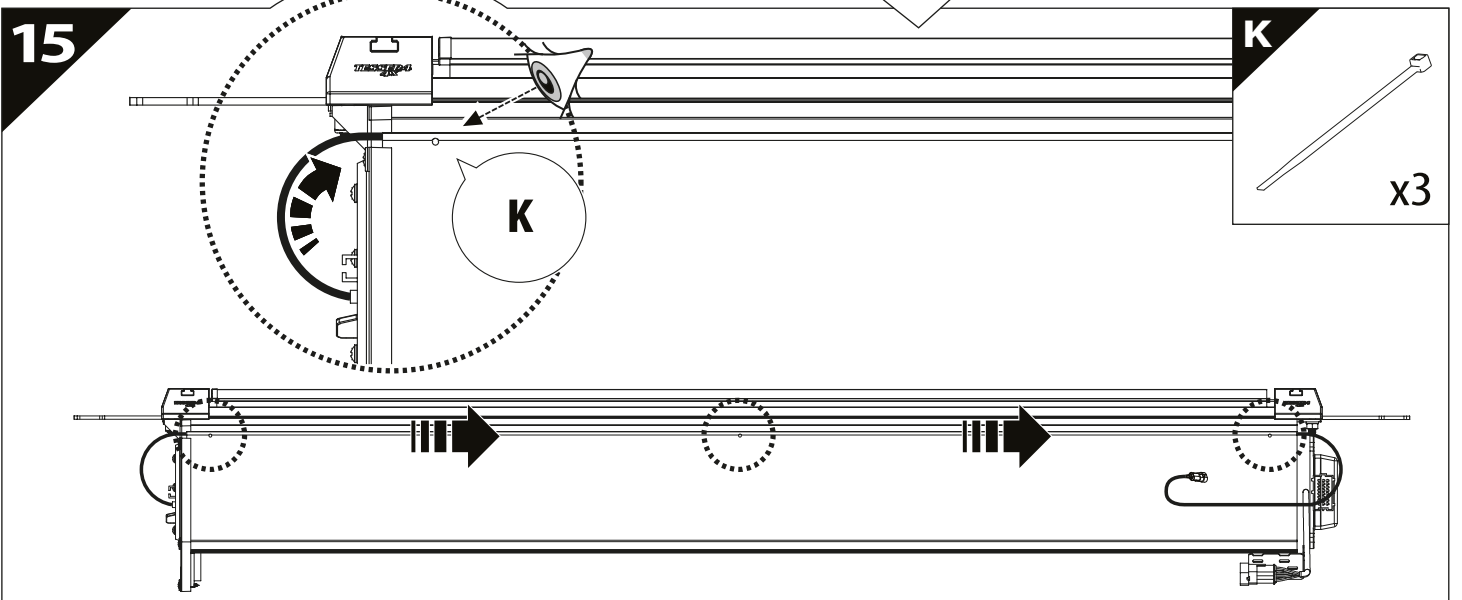
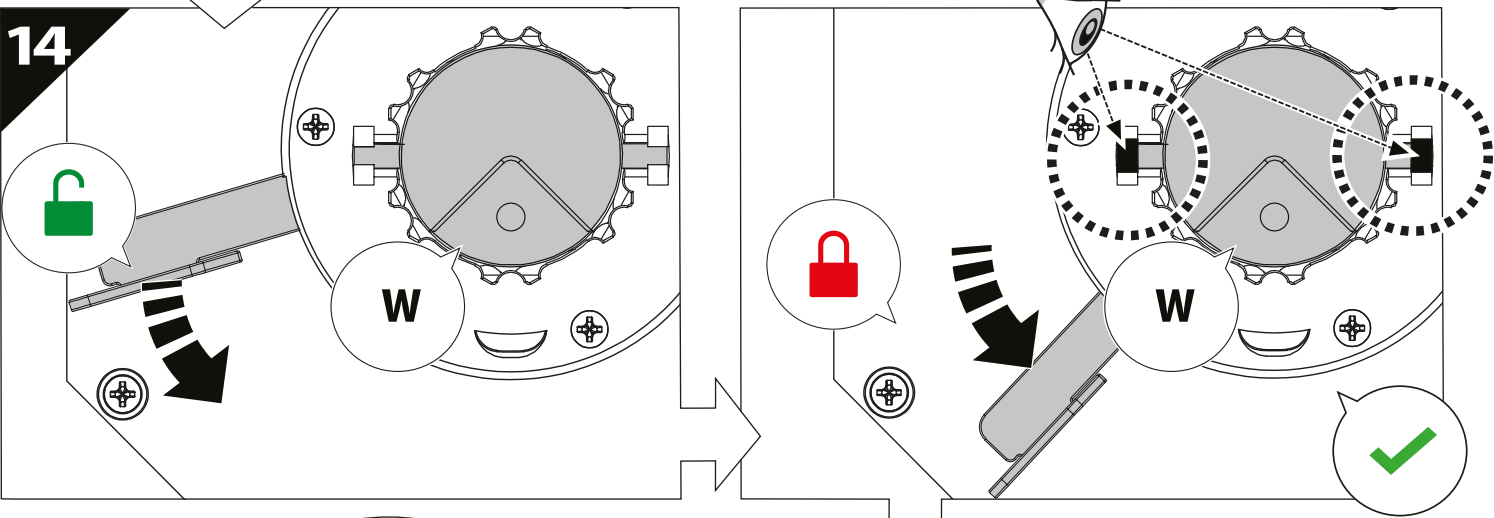
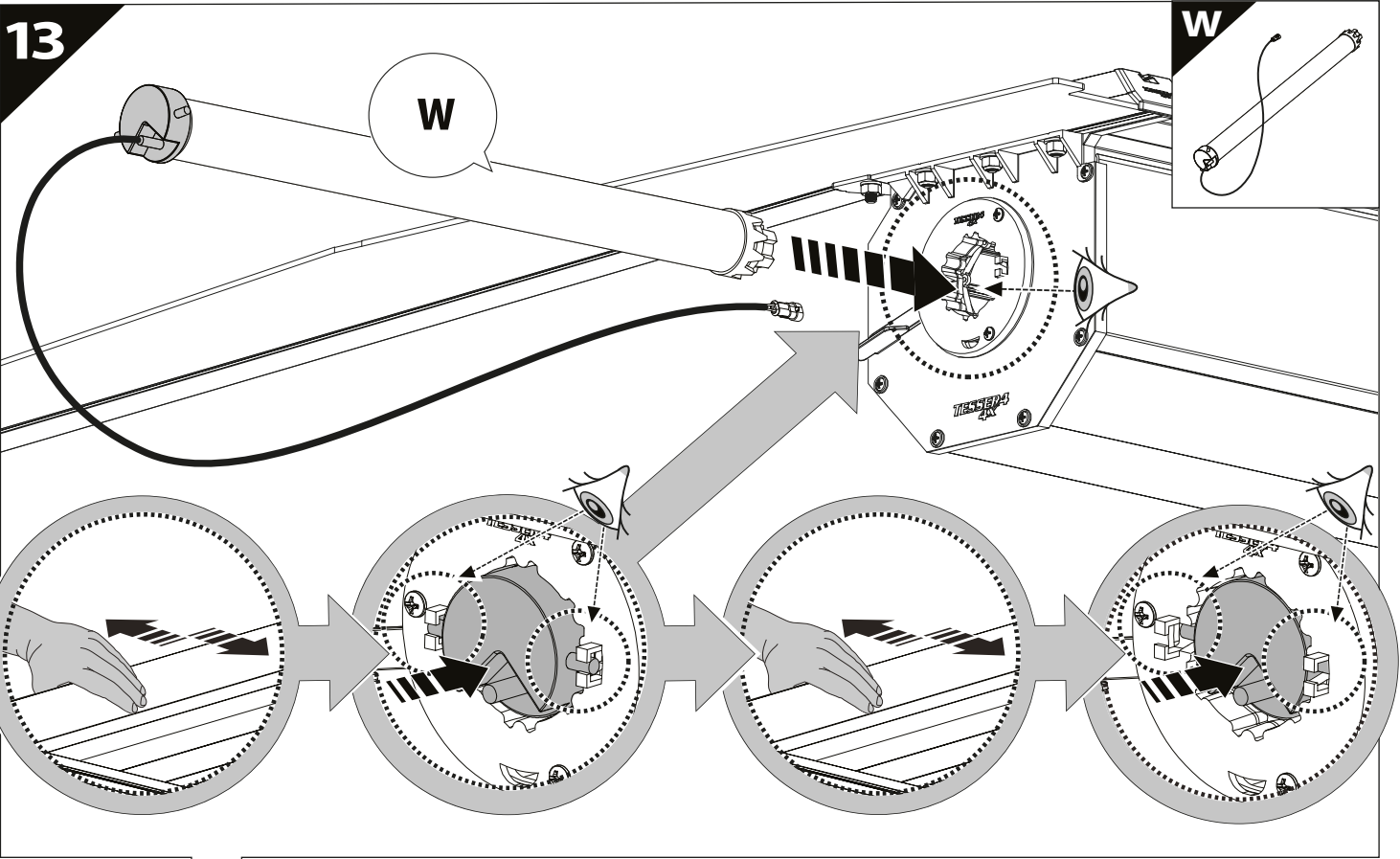

16

U

D1

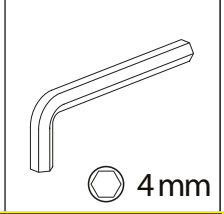
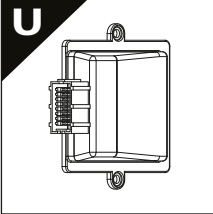

4mm

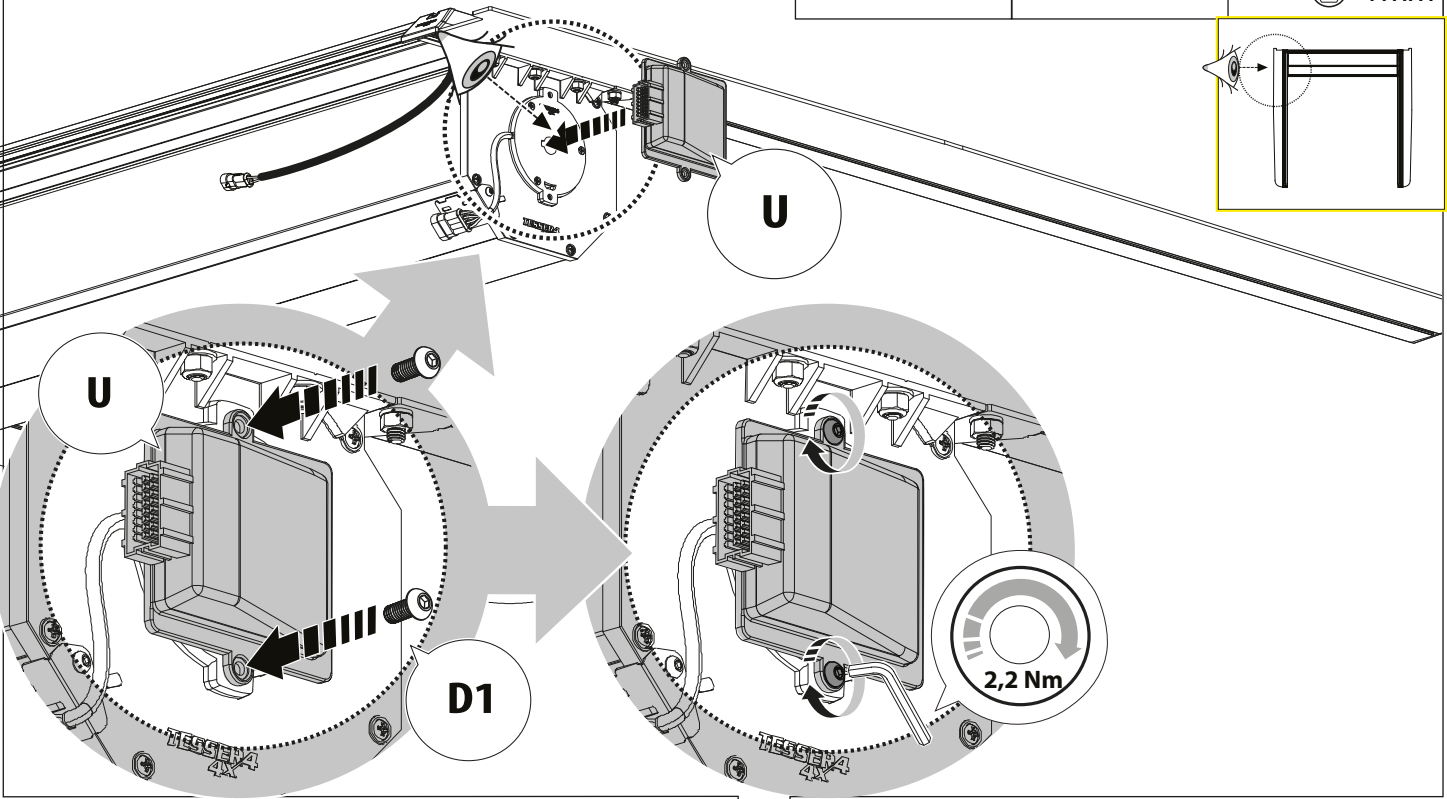
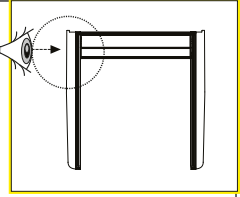

17

U

M2

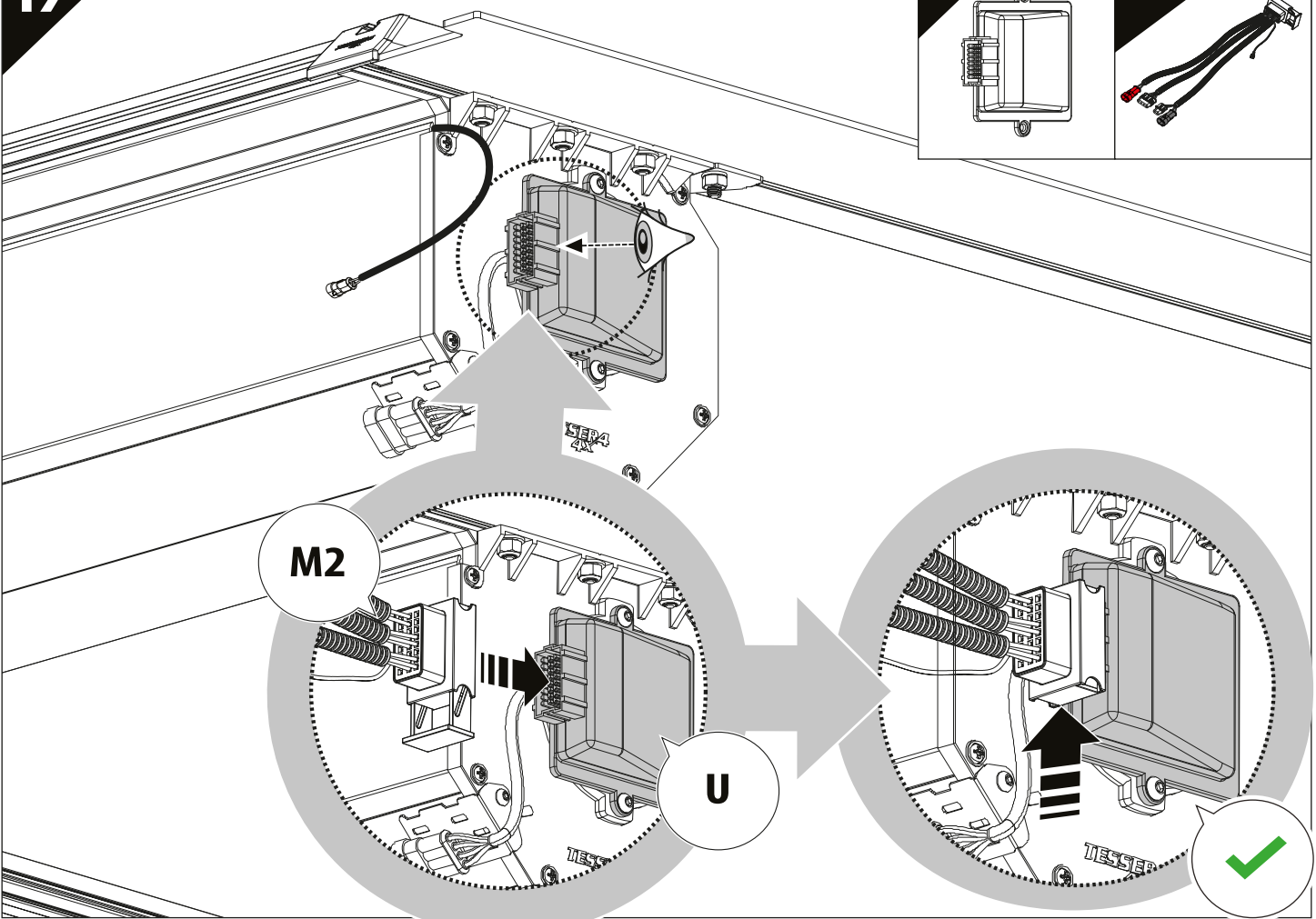
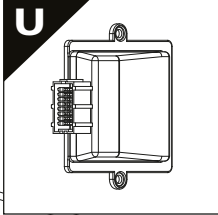

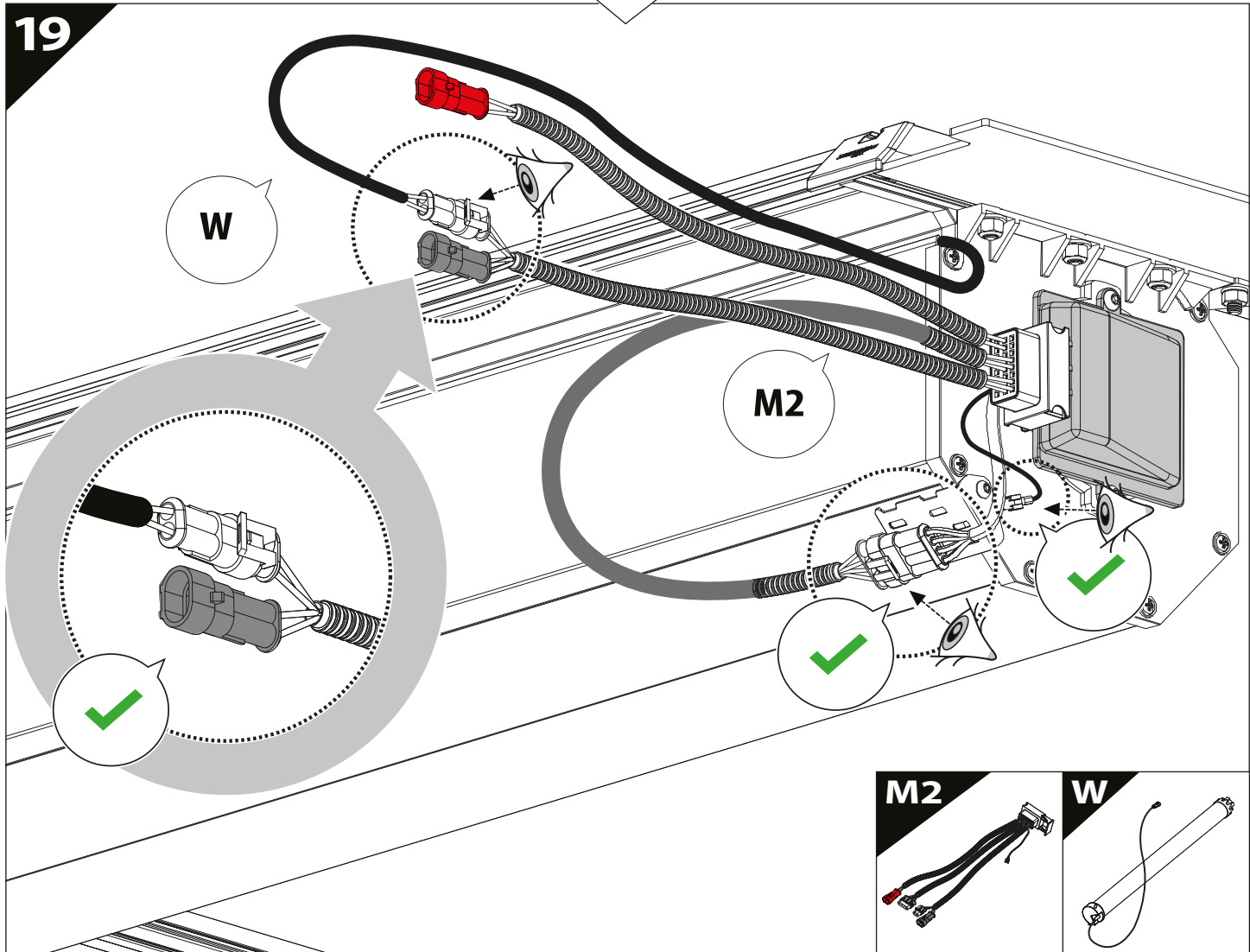
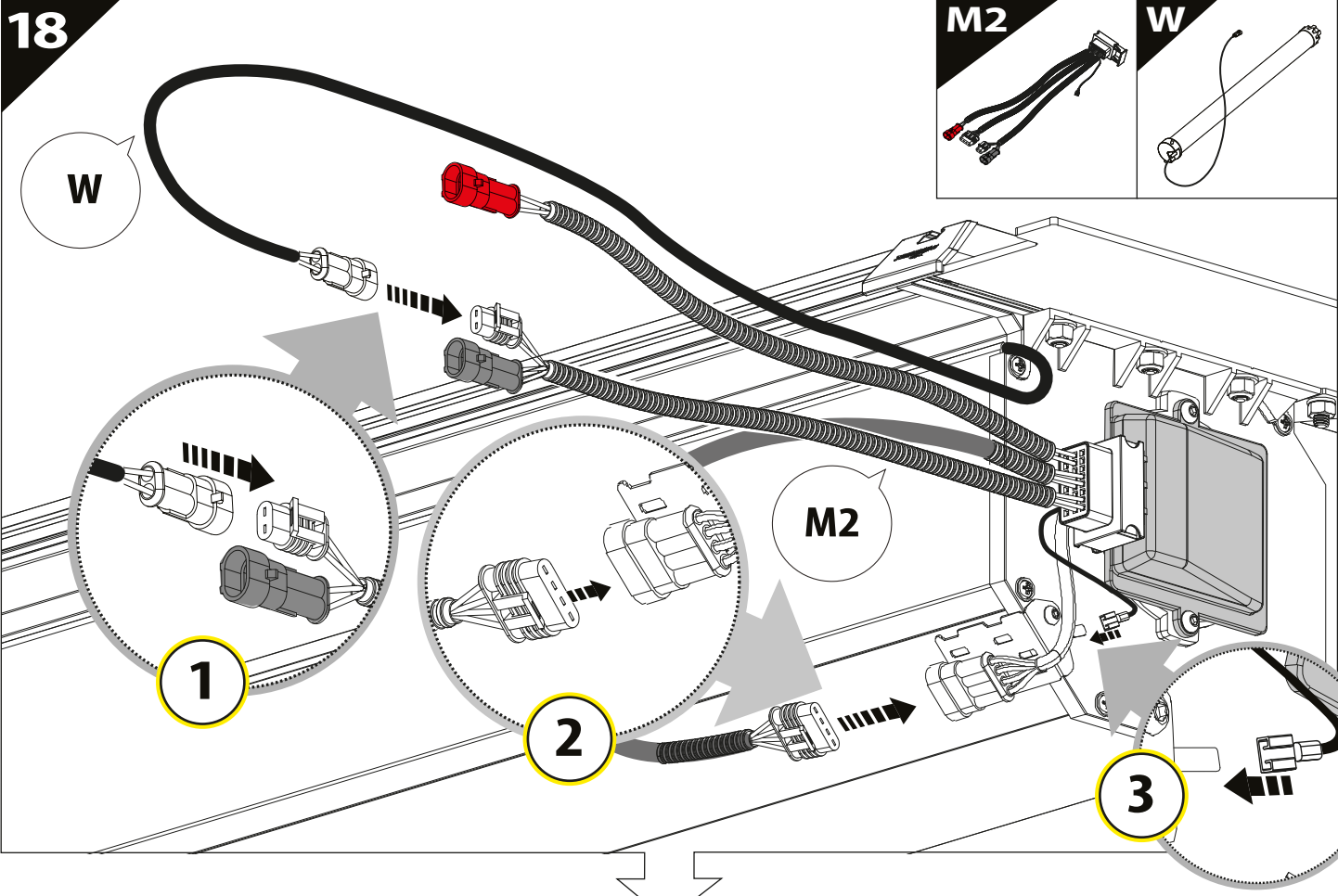

20

K

x2

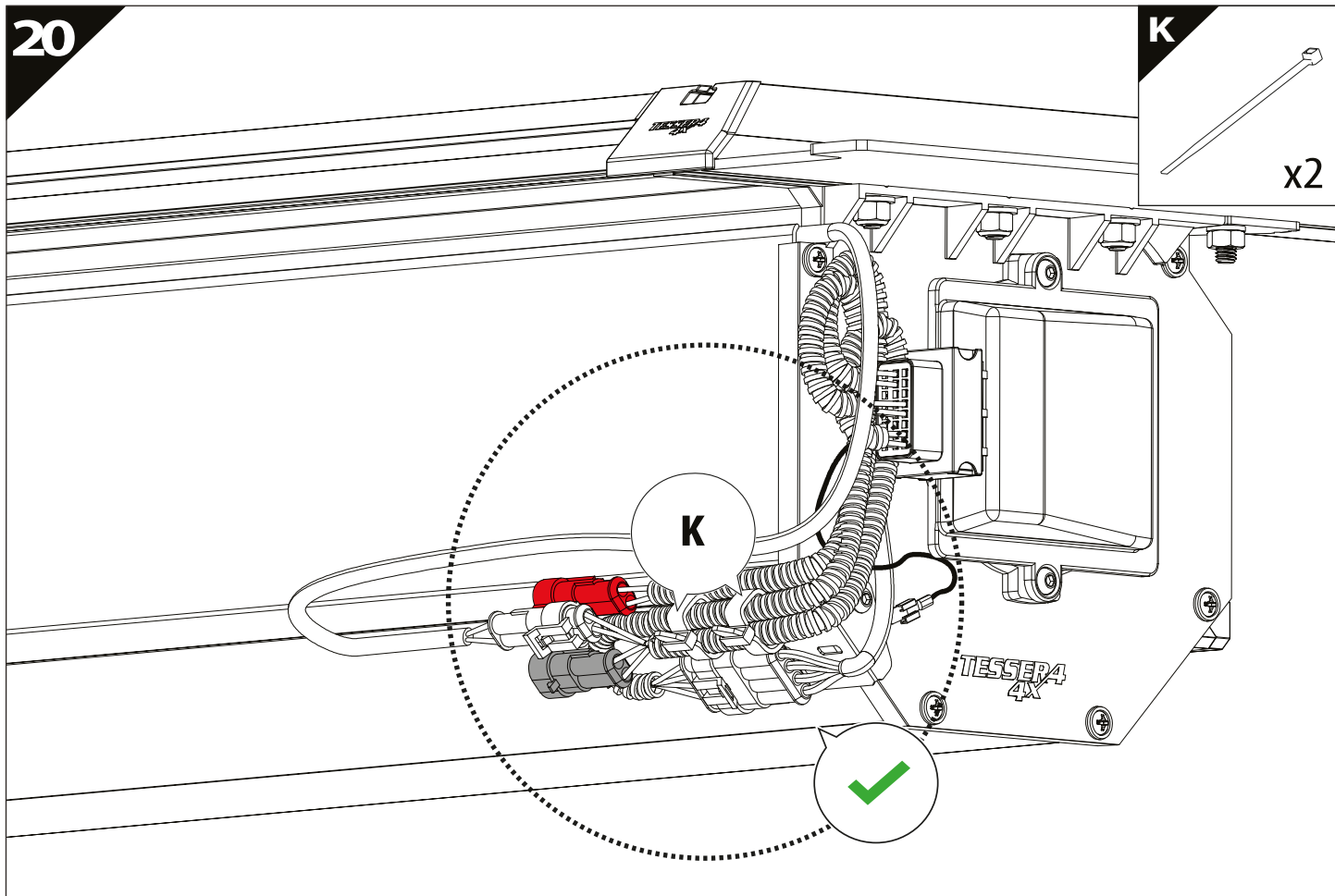

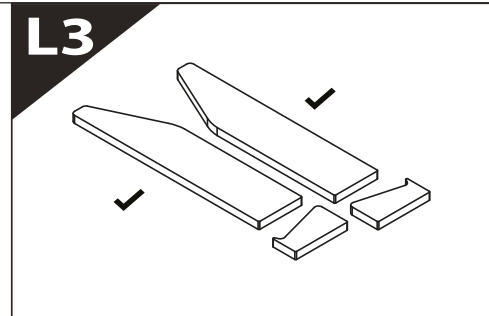
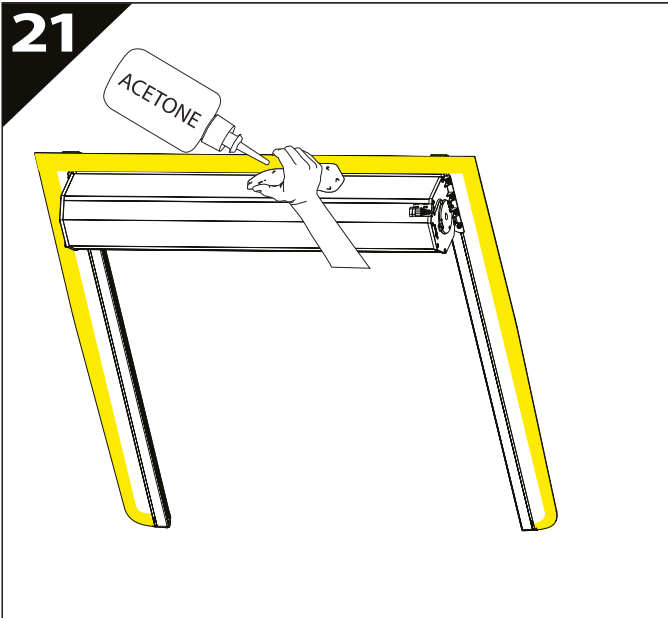

L3



22

L3

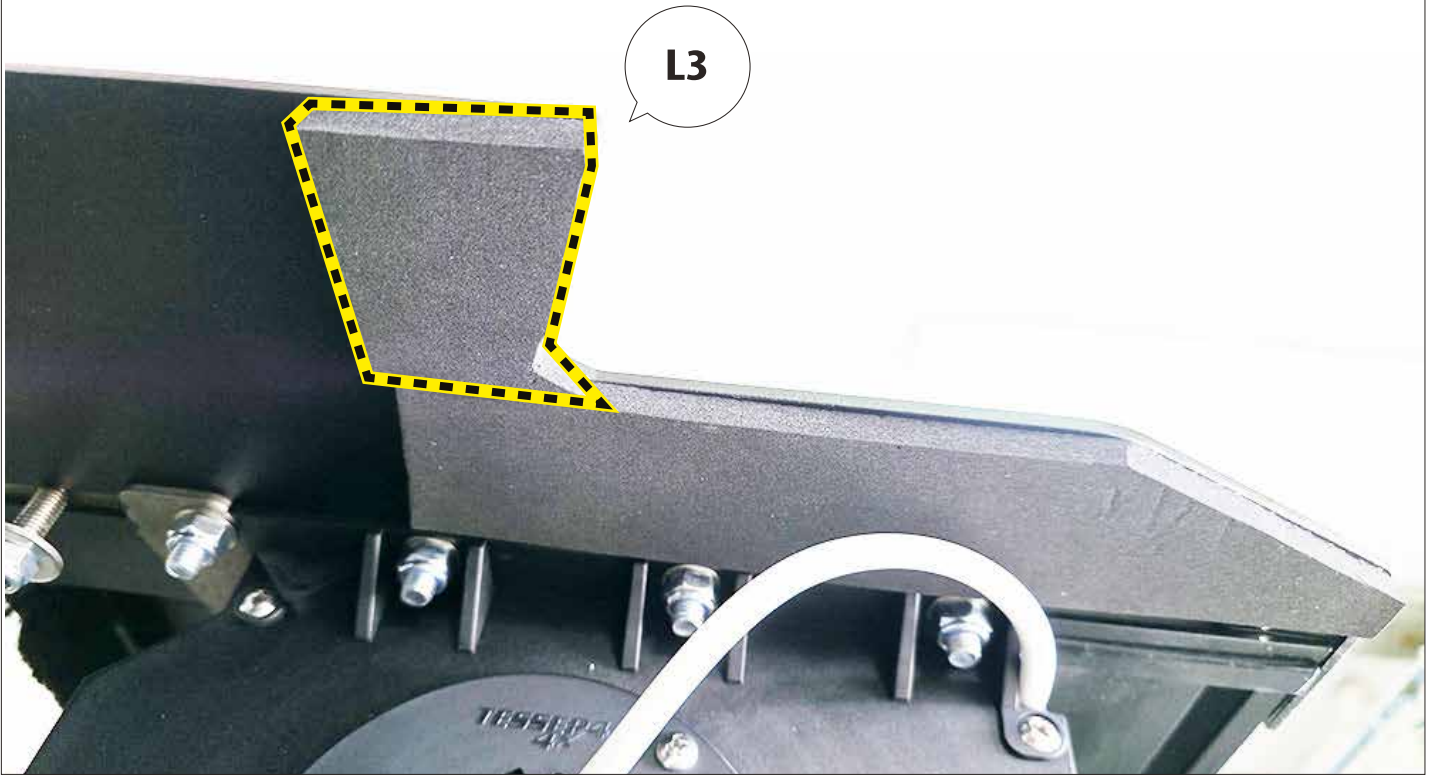
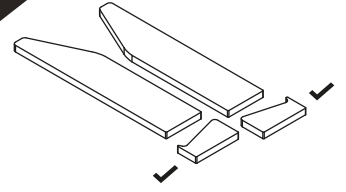

23

L2

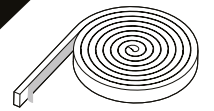

5 x 0.8 x 167cm

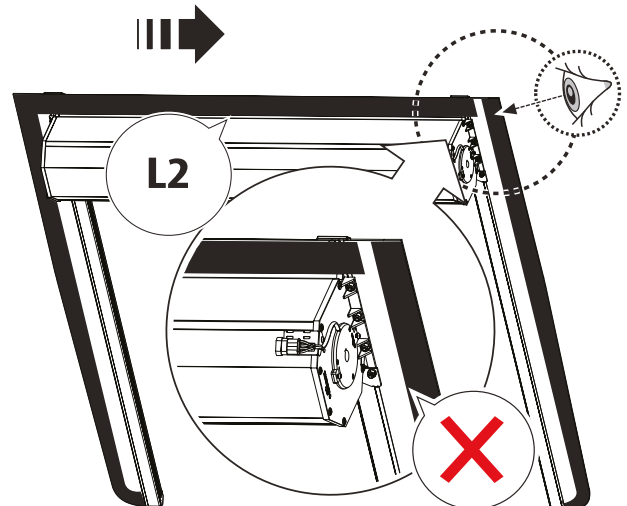
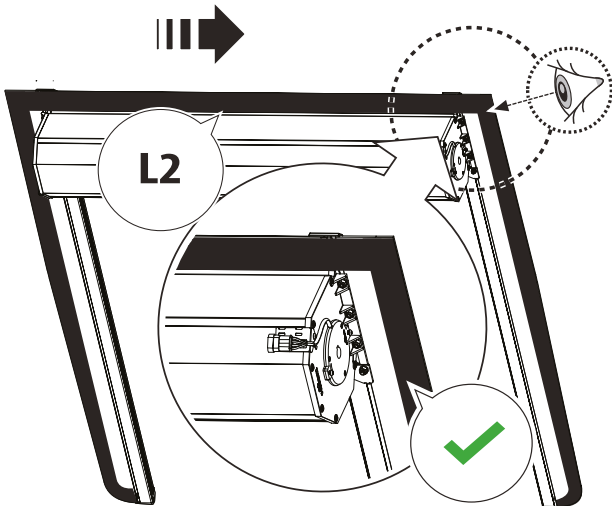

24

L1

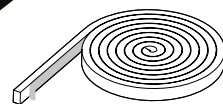

1.5 x 0.8 x 400cm

L1

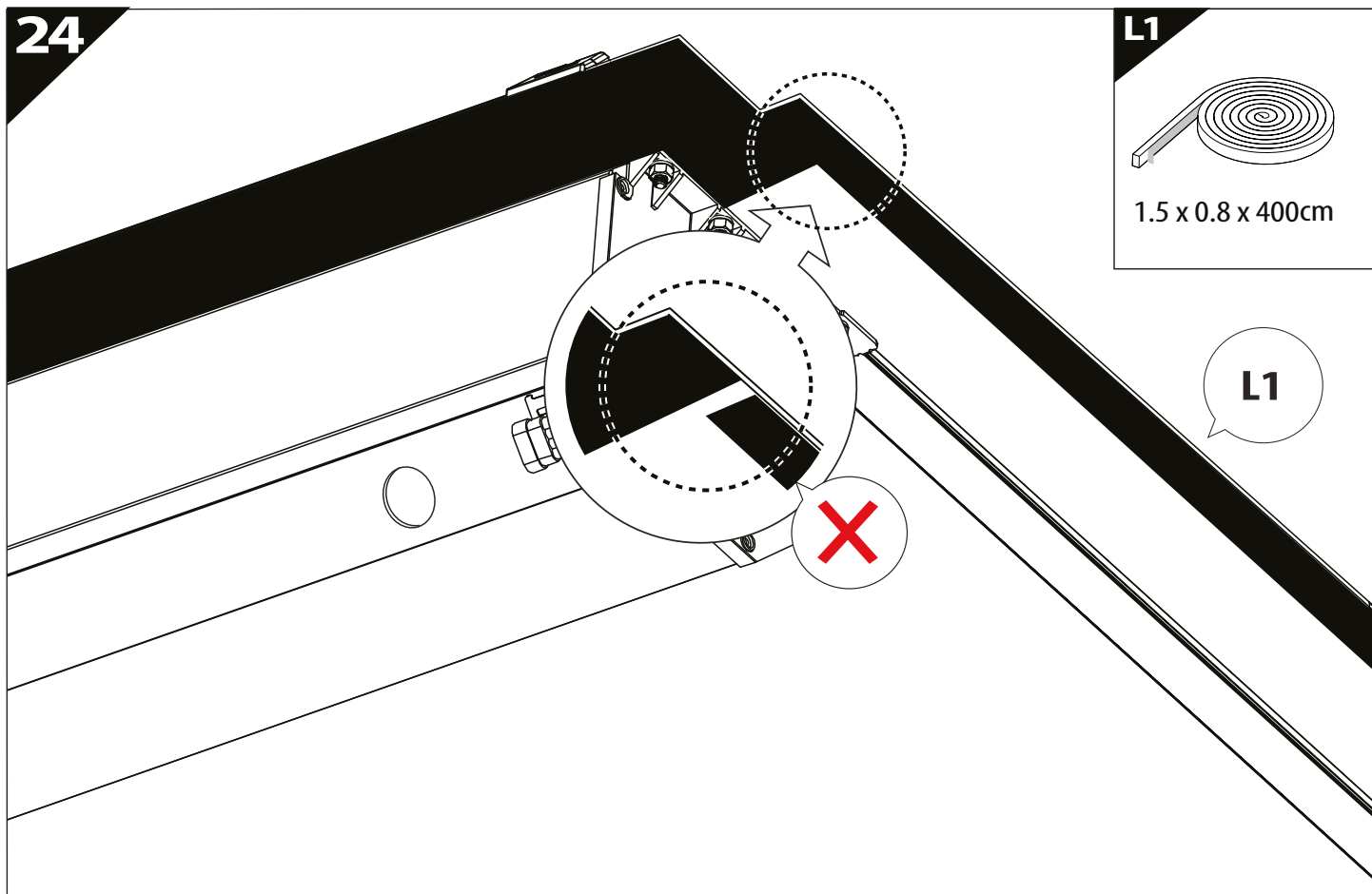

25



26



27

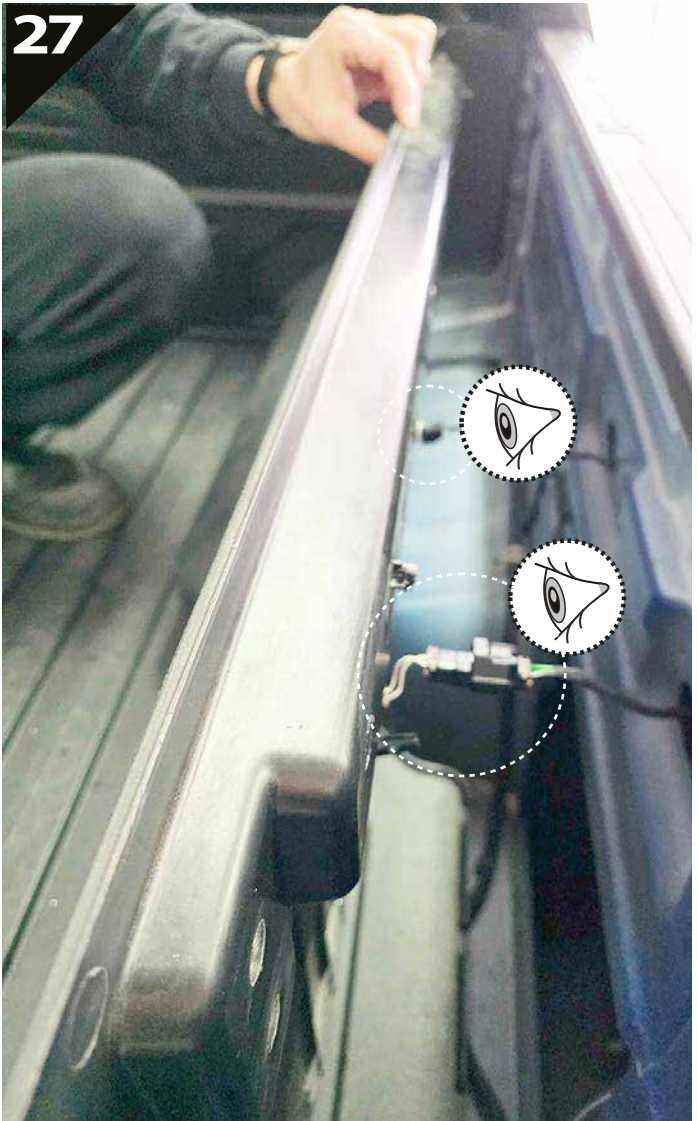



30



31



32



33



RE - USE IN STEP 28 (5 out of 9) 

34



35



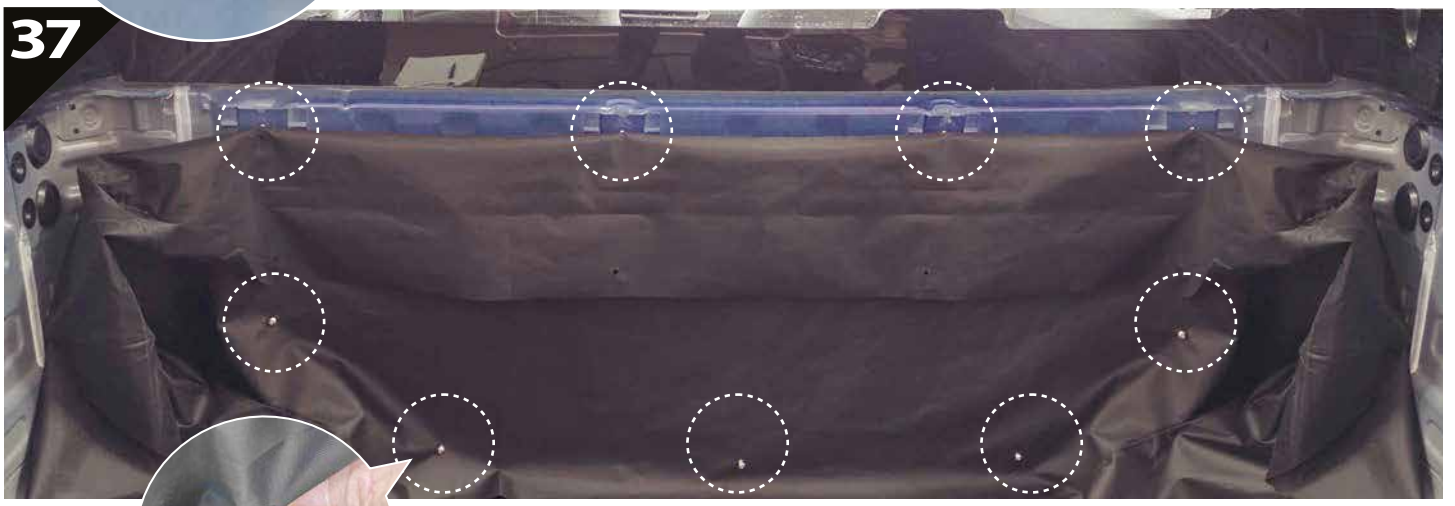
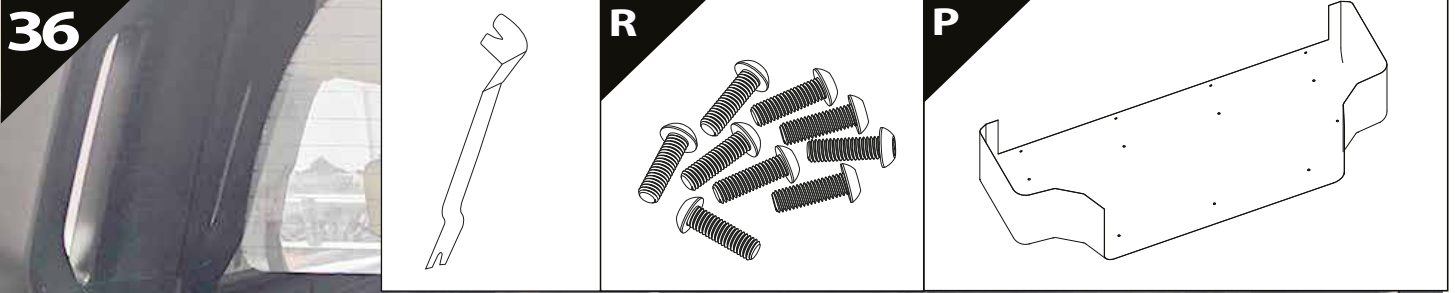

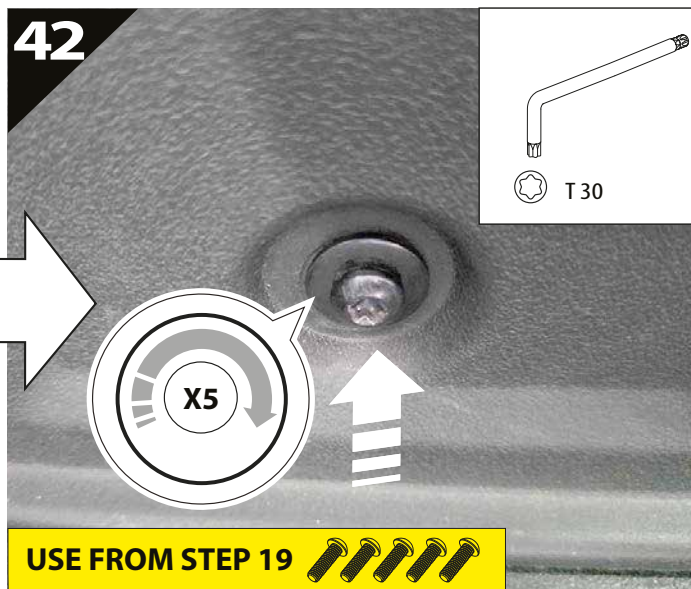
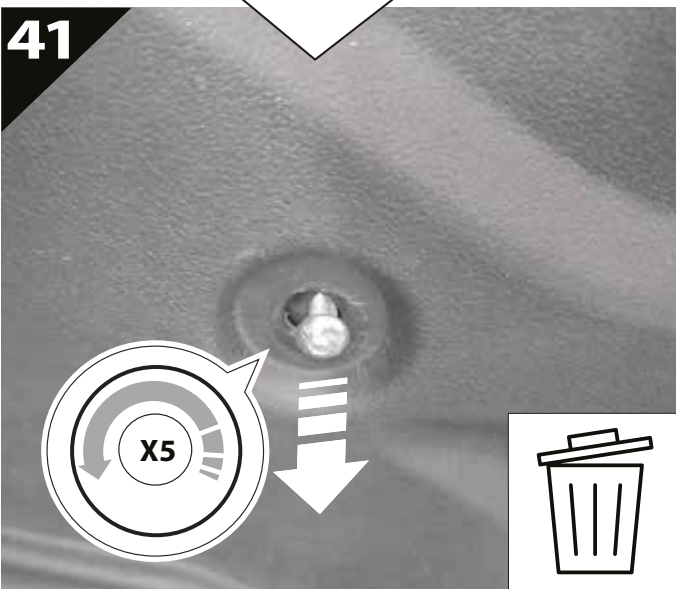

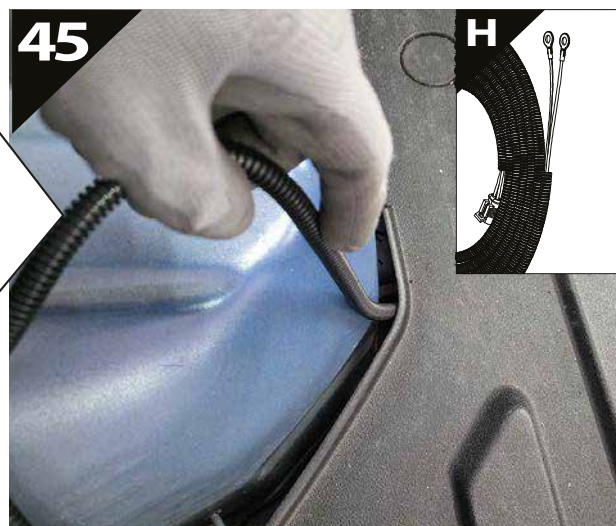
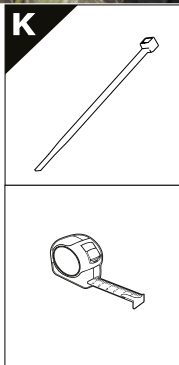
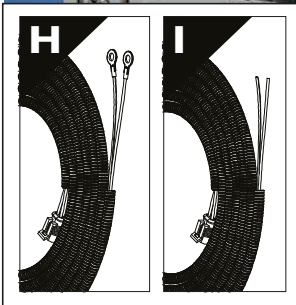
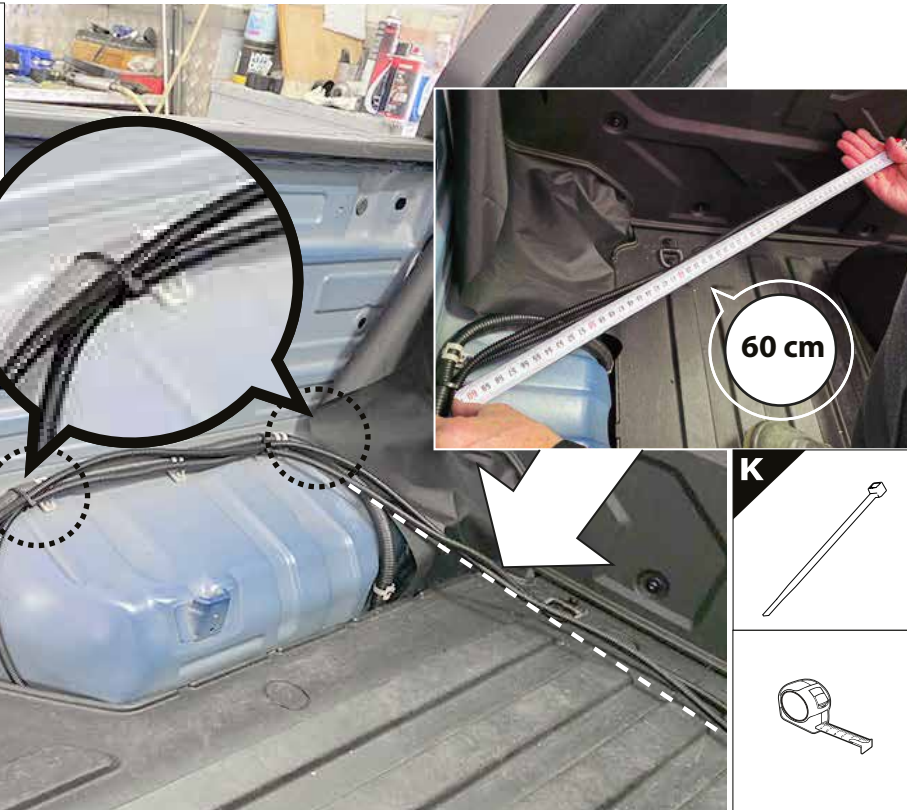
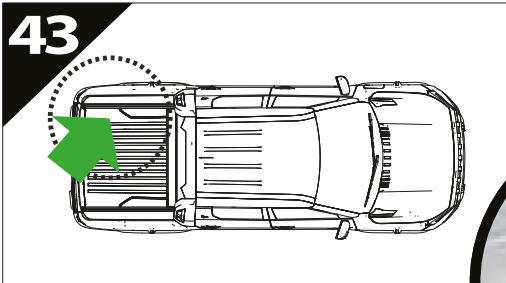

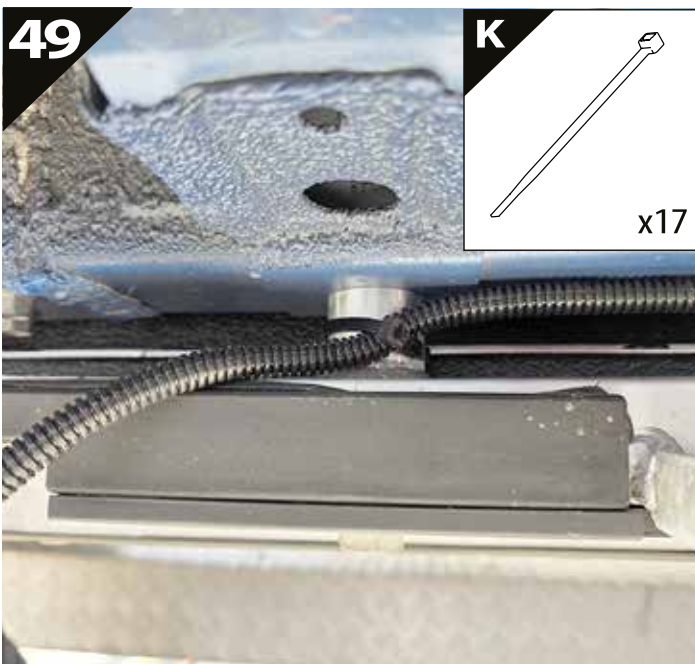
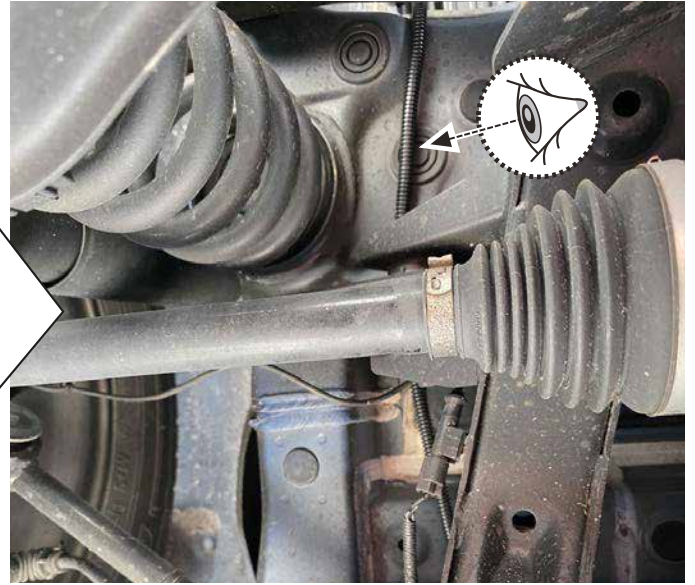
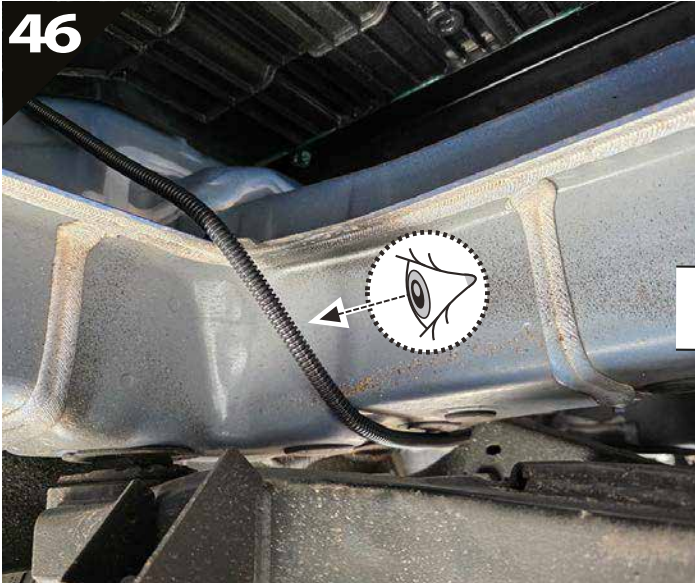

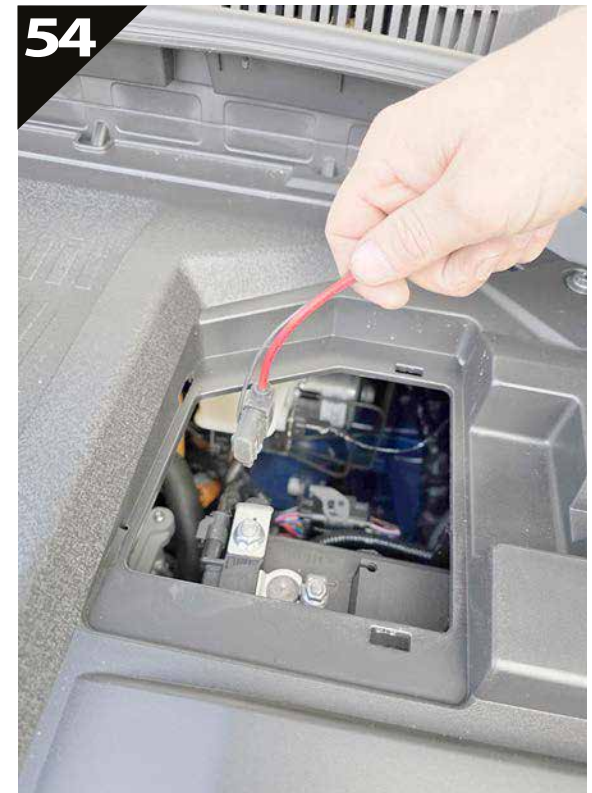
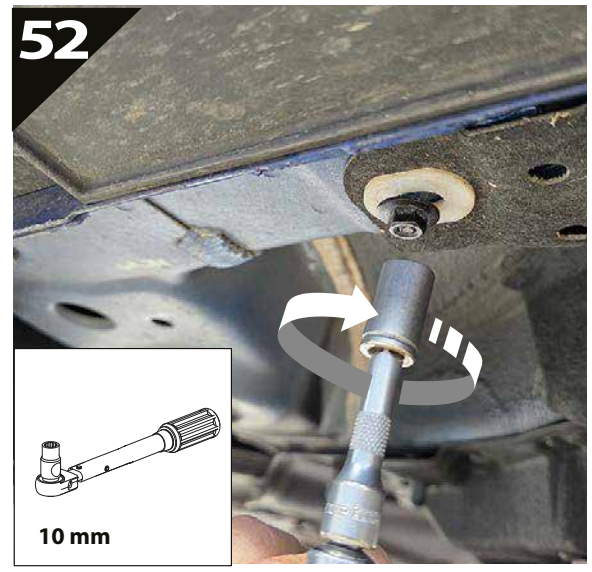
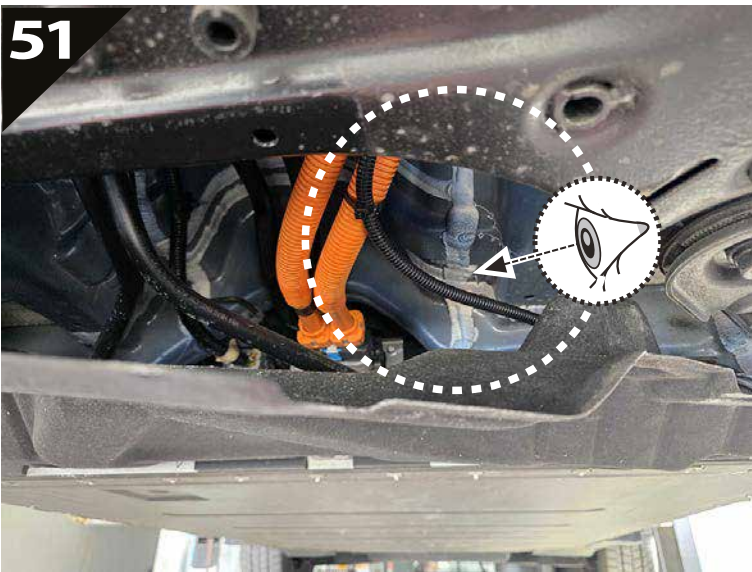
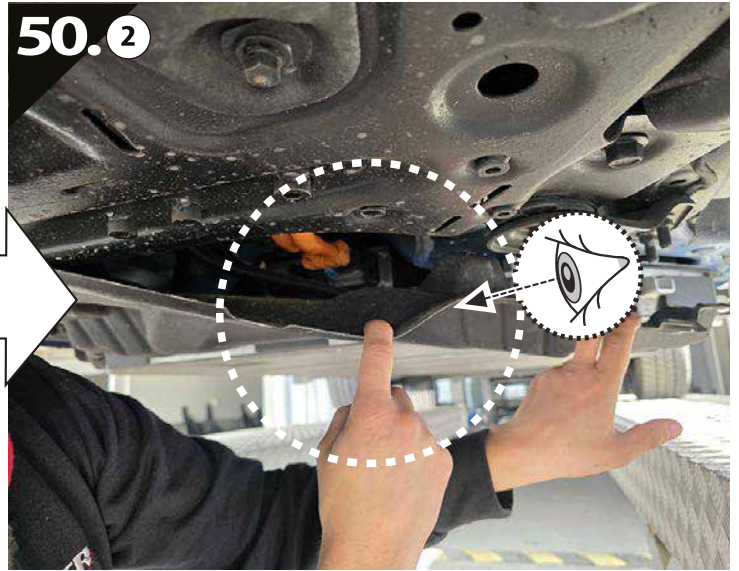
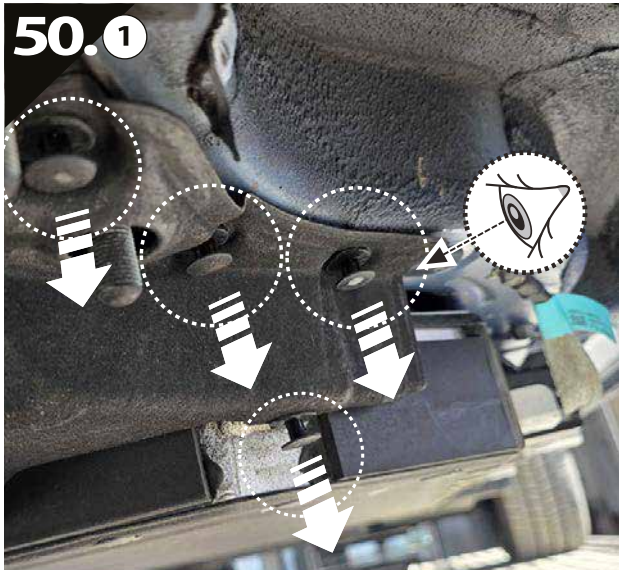

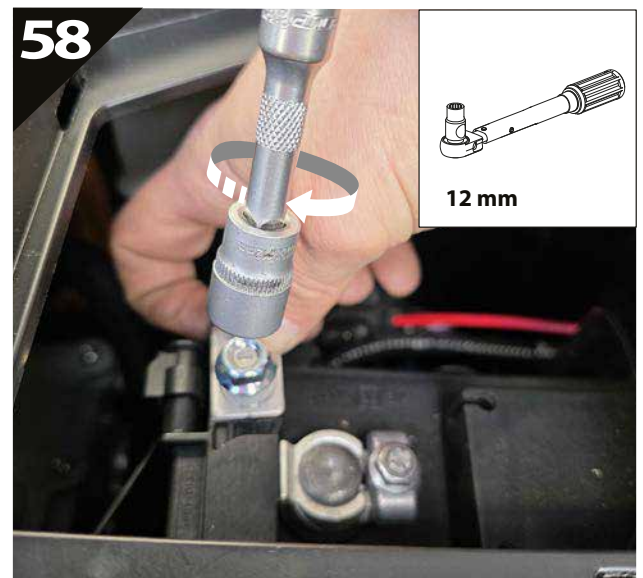
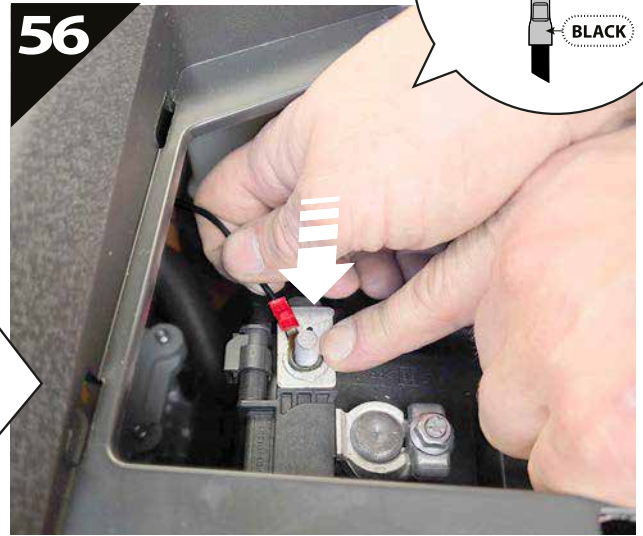
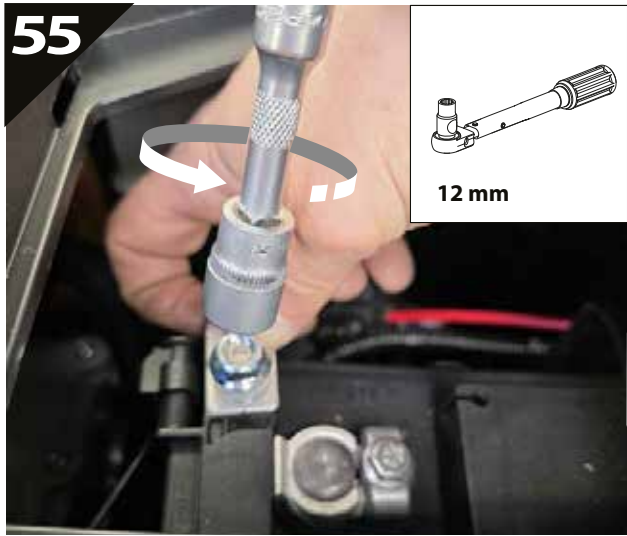

60

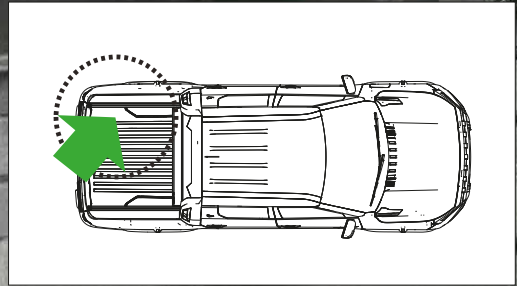

61

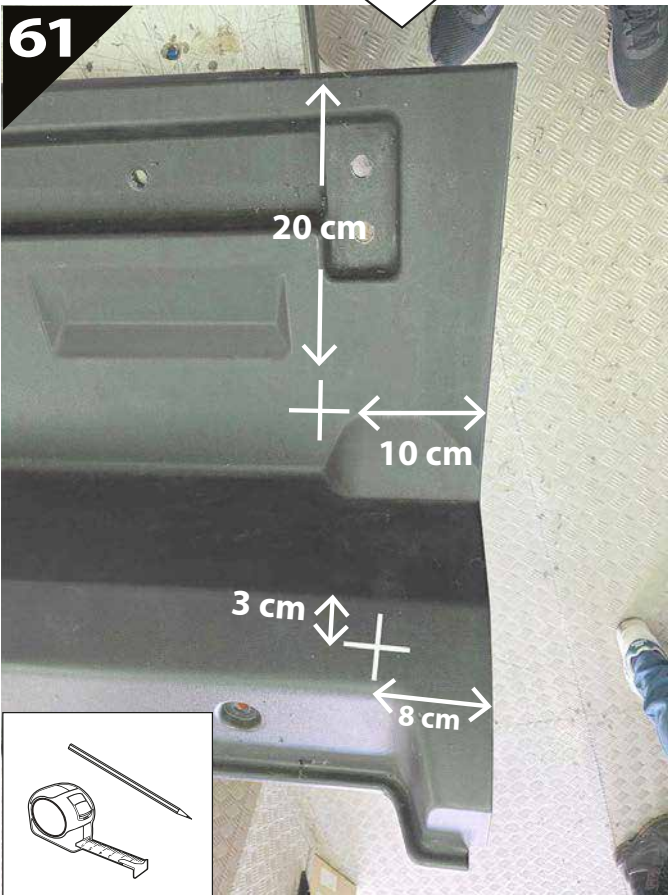

62

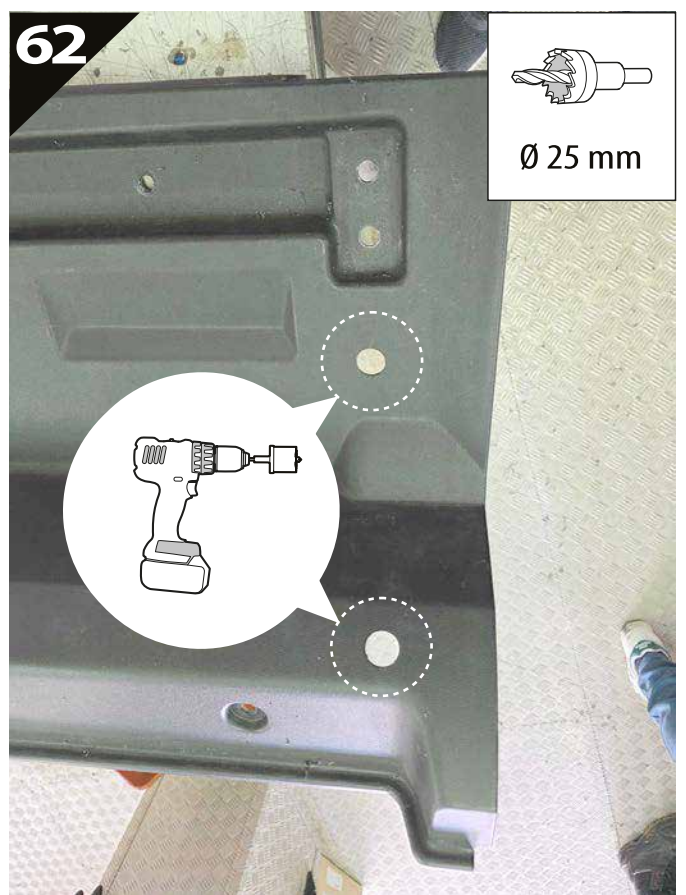

63

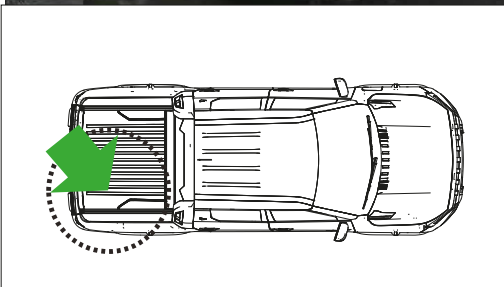

64



65

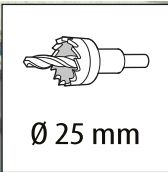

66

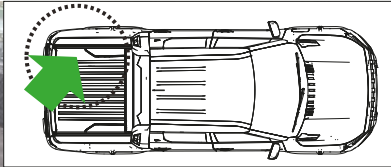

67

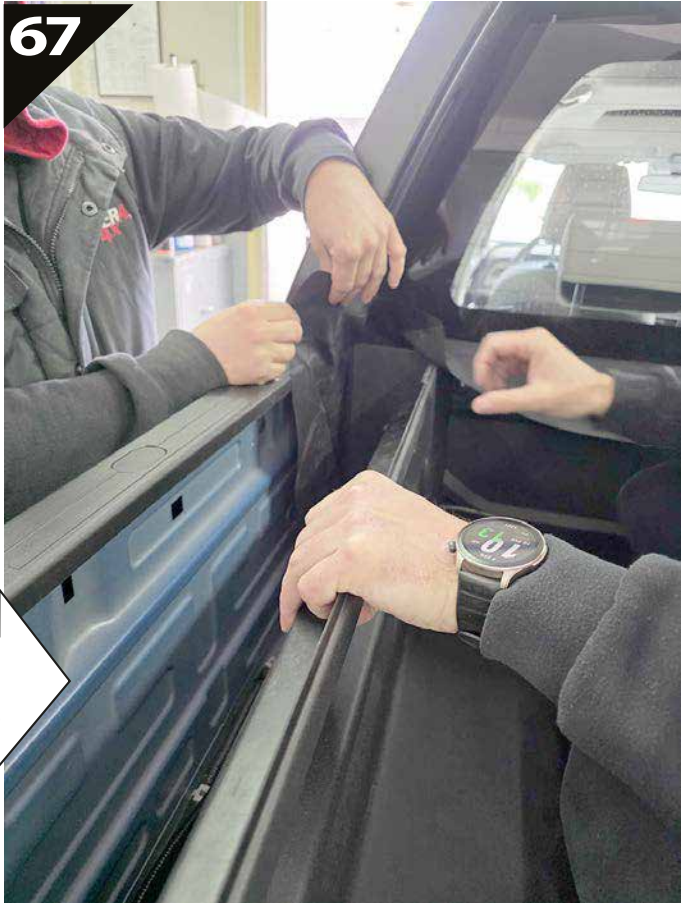

68



69

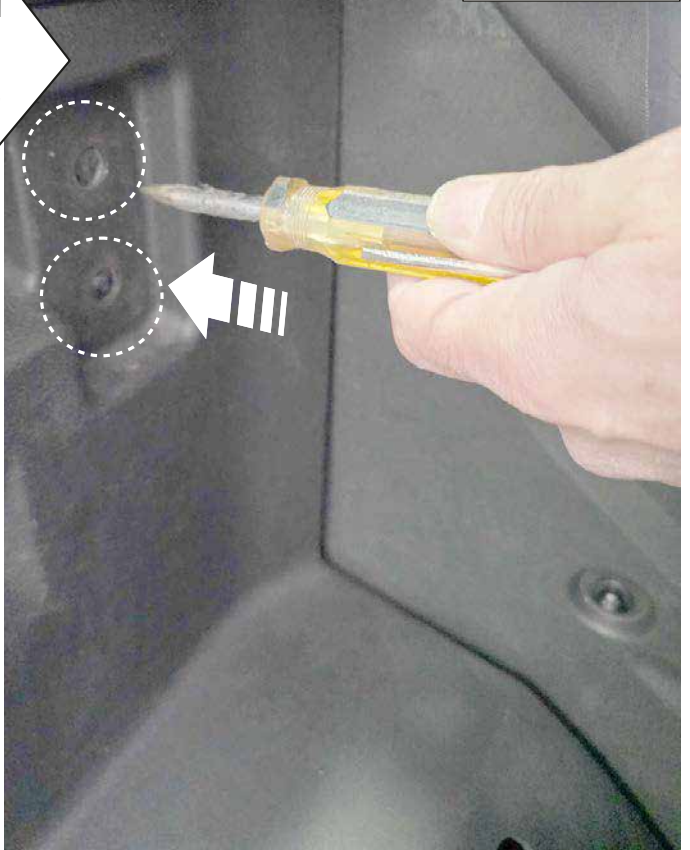
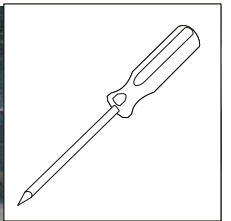

70



N

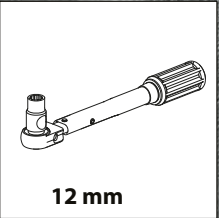
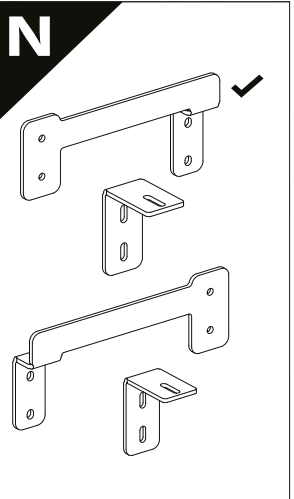

12 mm

71

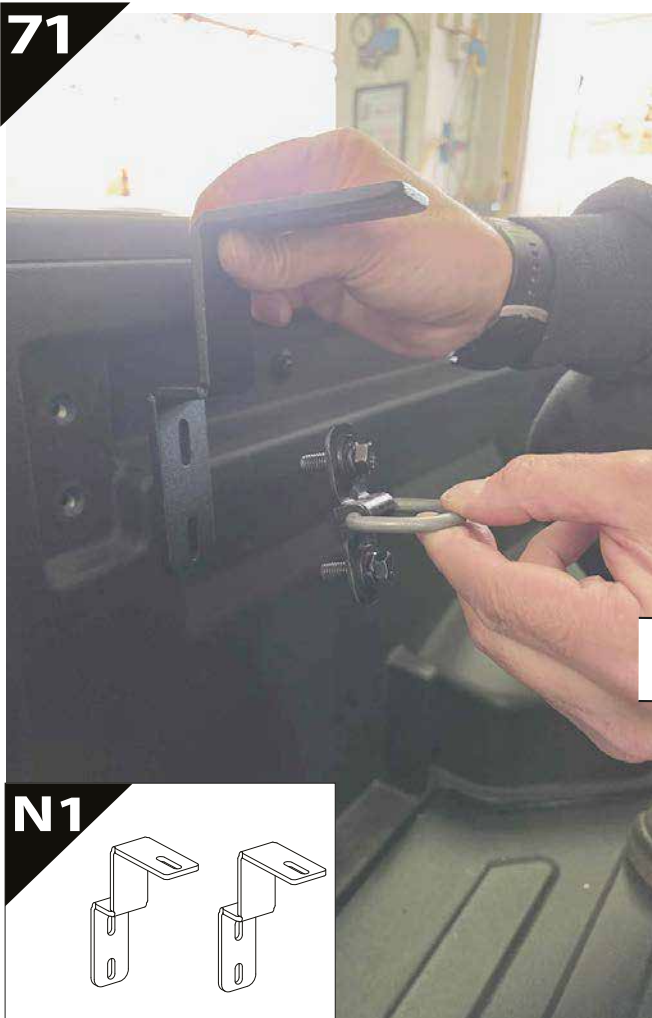

N1

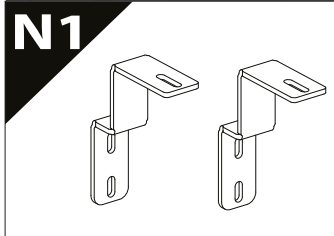

72

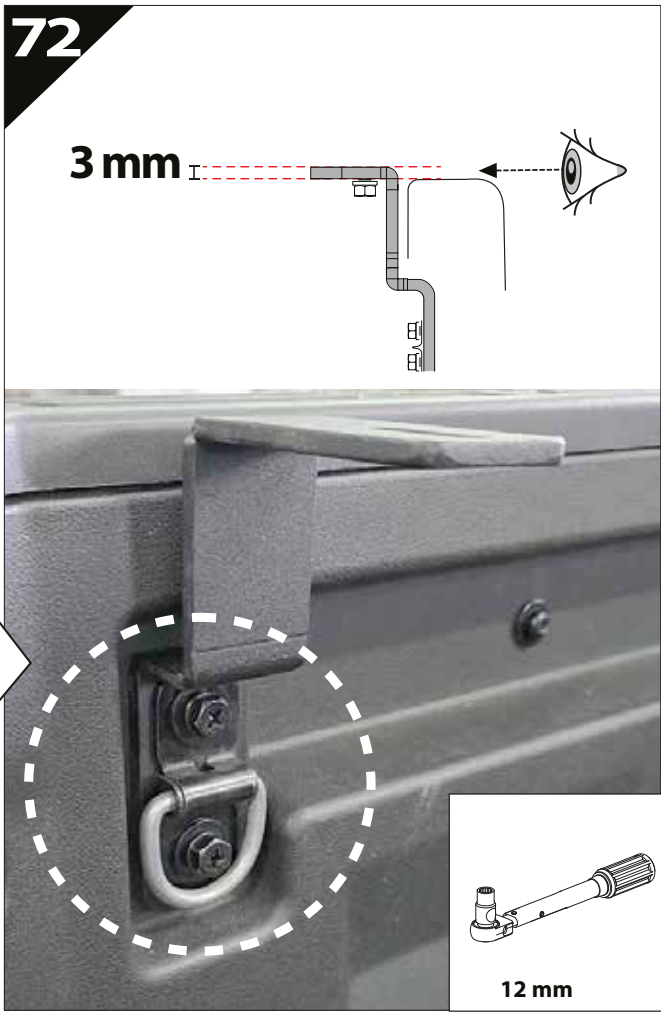

3 mm

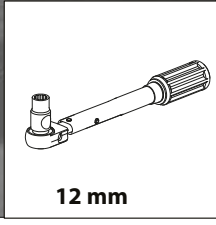

12 mm

73

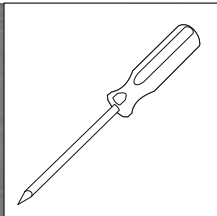

74

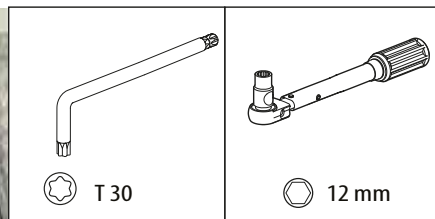

75

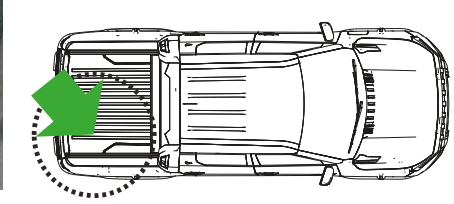

76



77



78

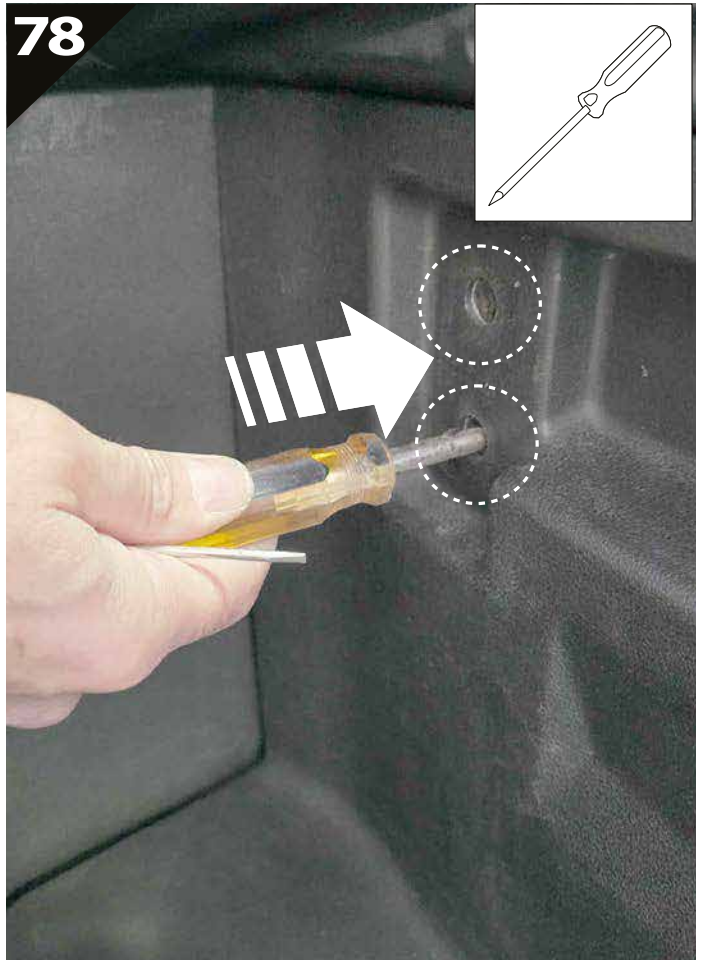

79

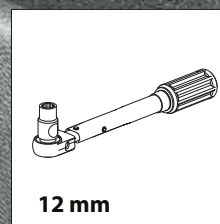
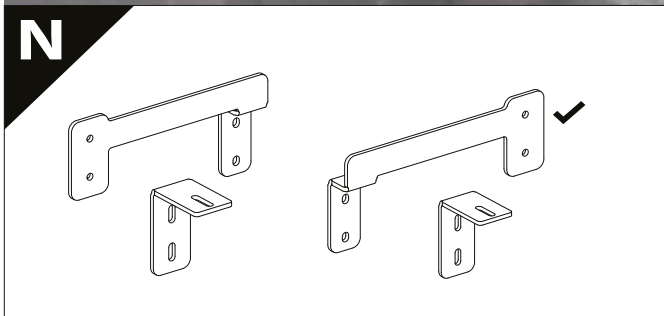

80

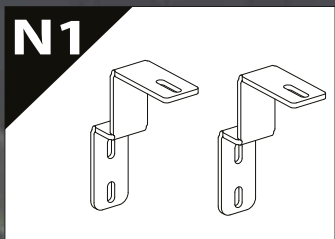

81

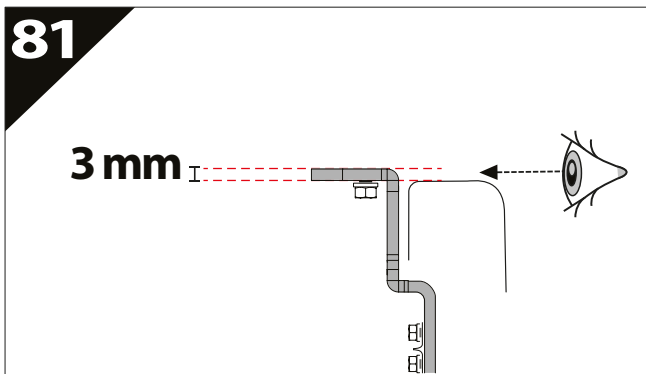

82

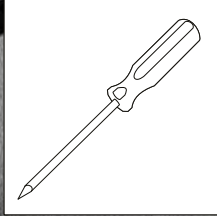
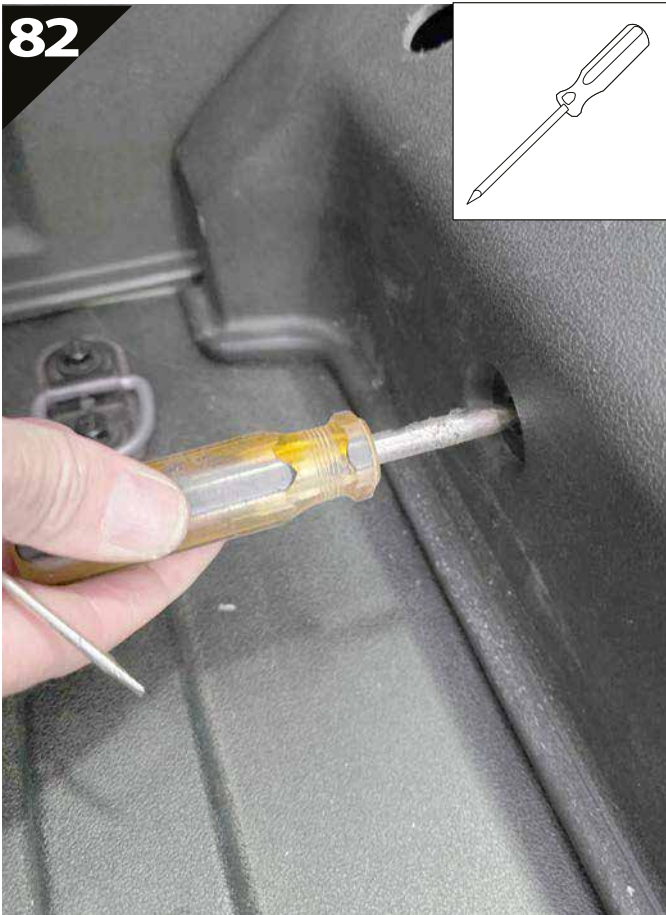

83

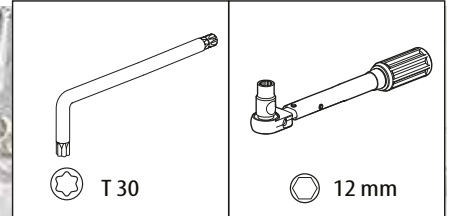

84



85



86



87





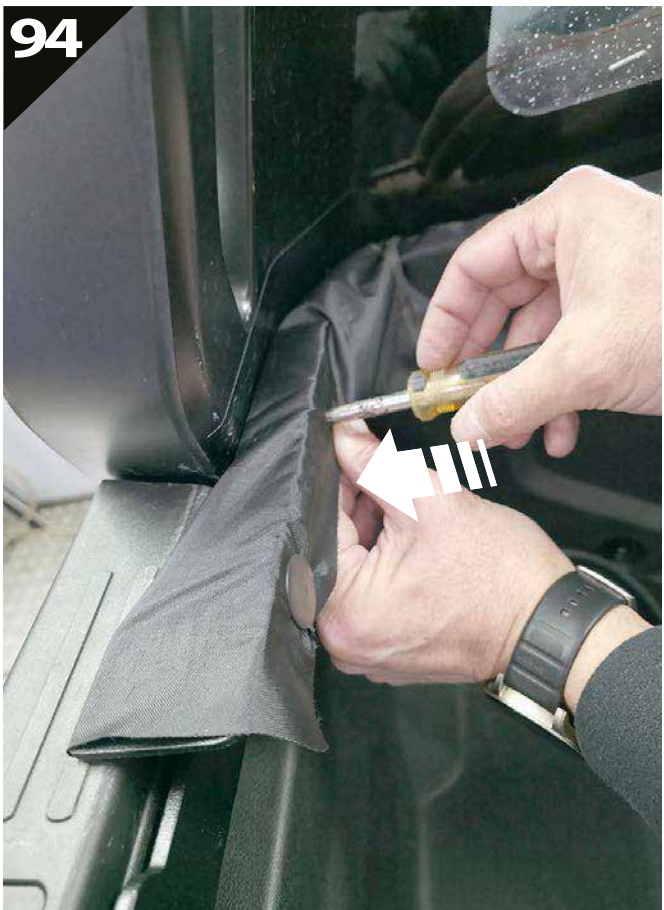
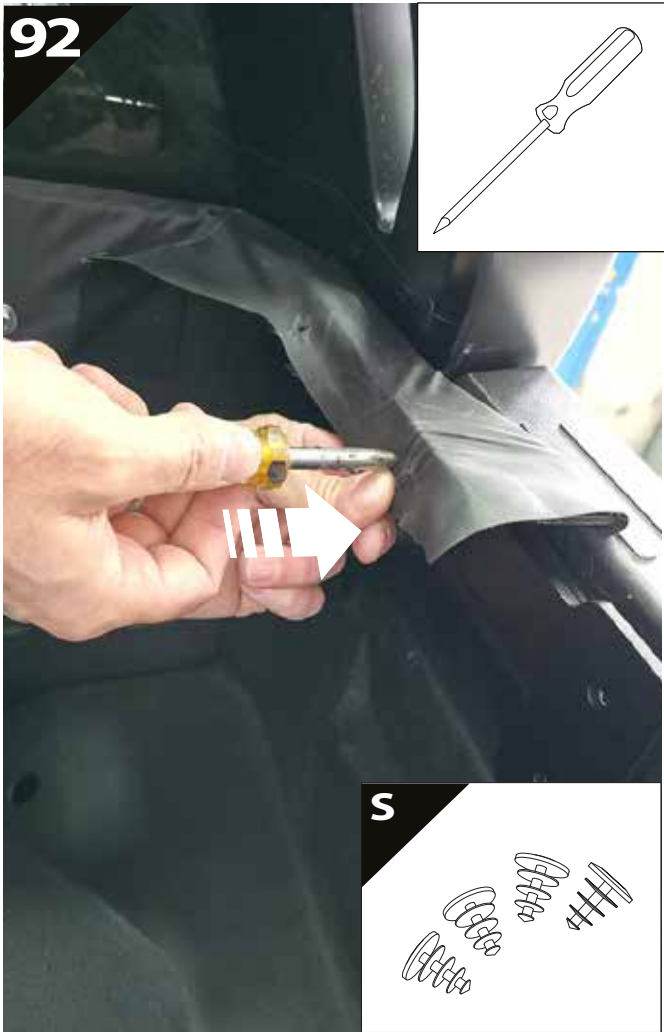



97



98

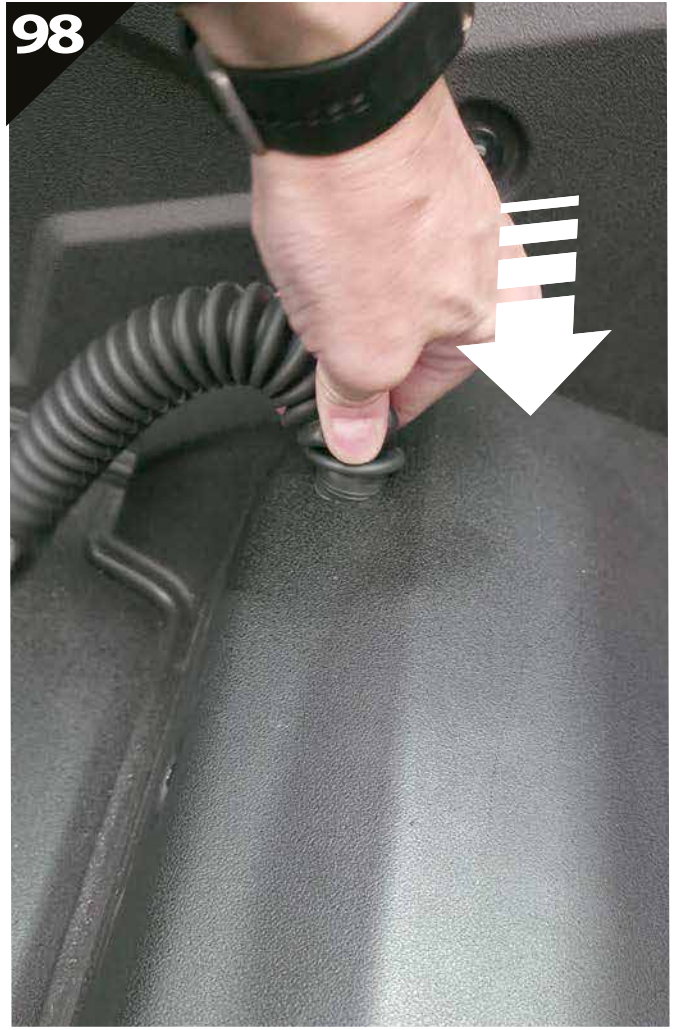

99





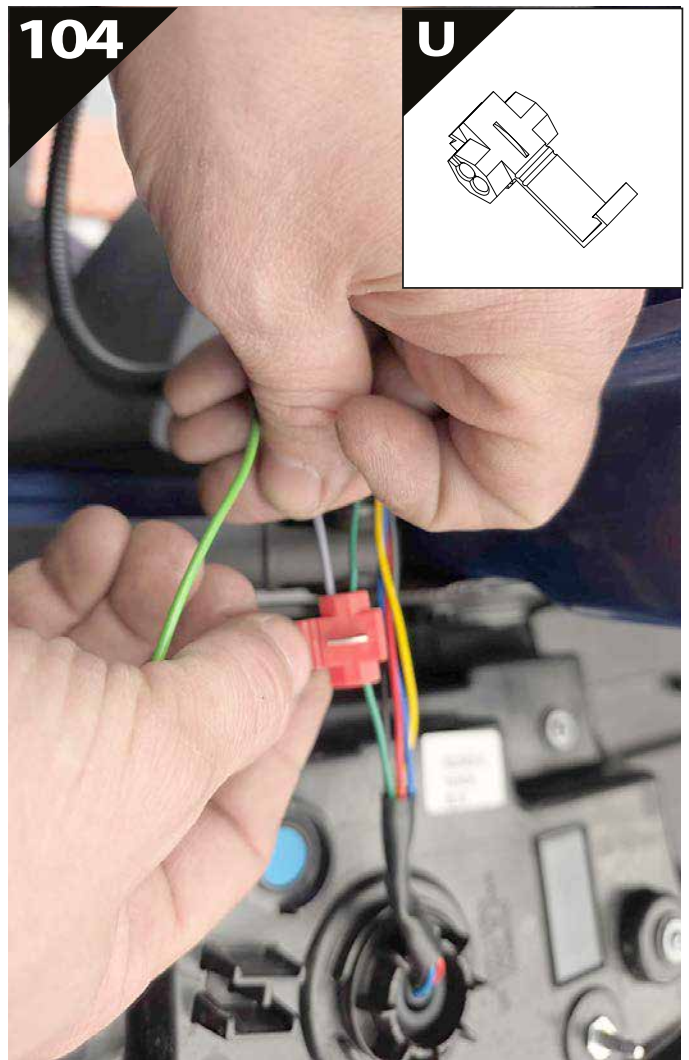
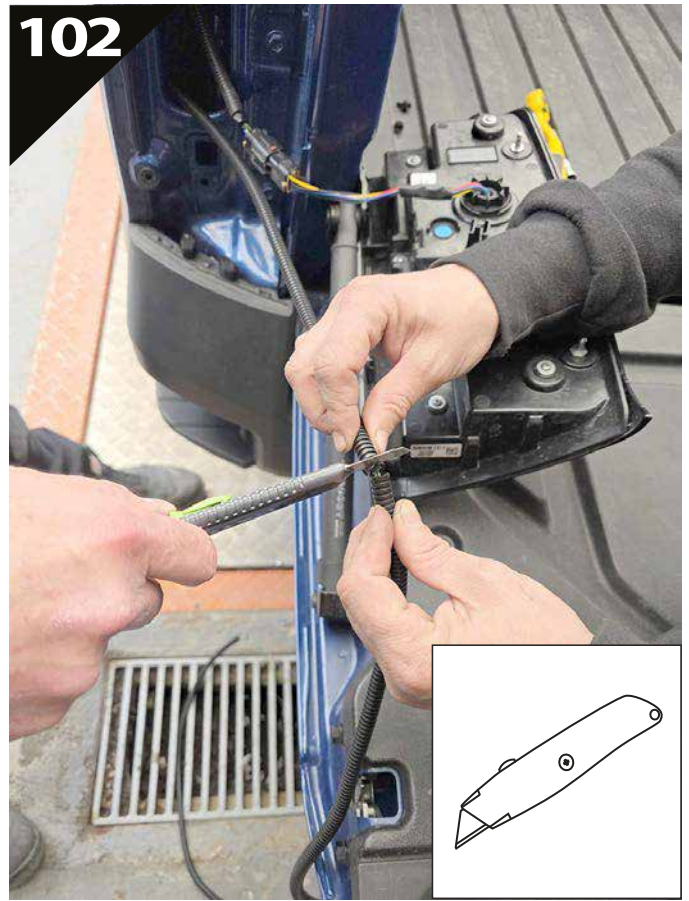

100



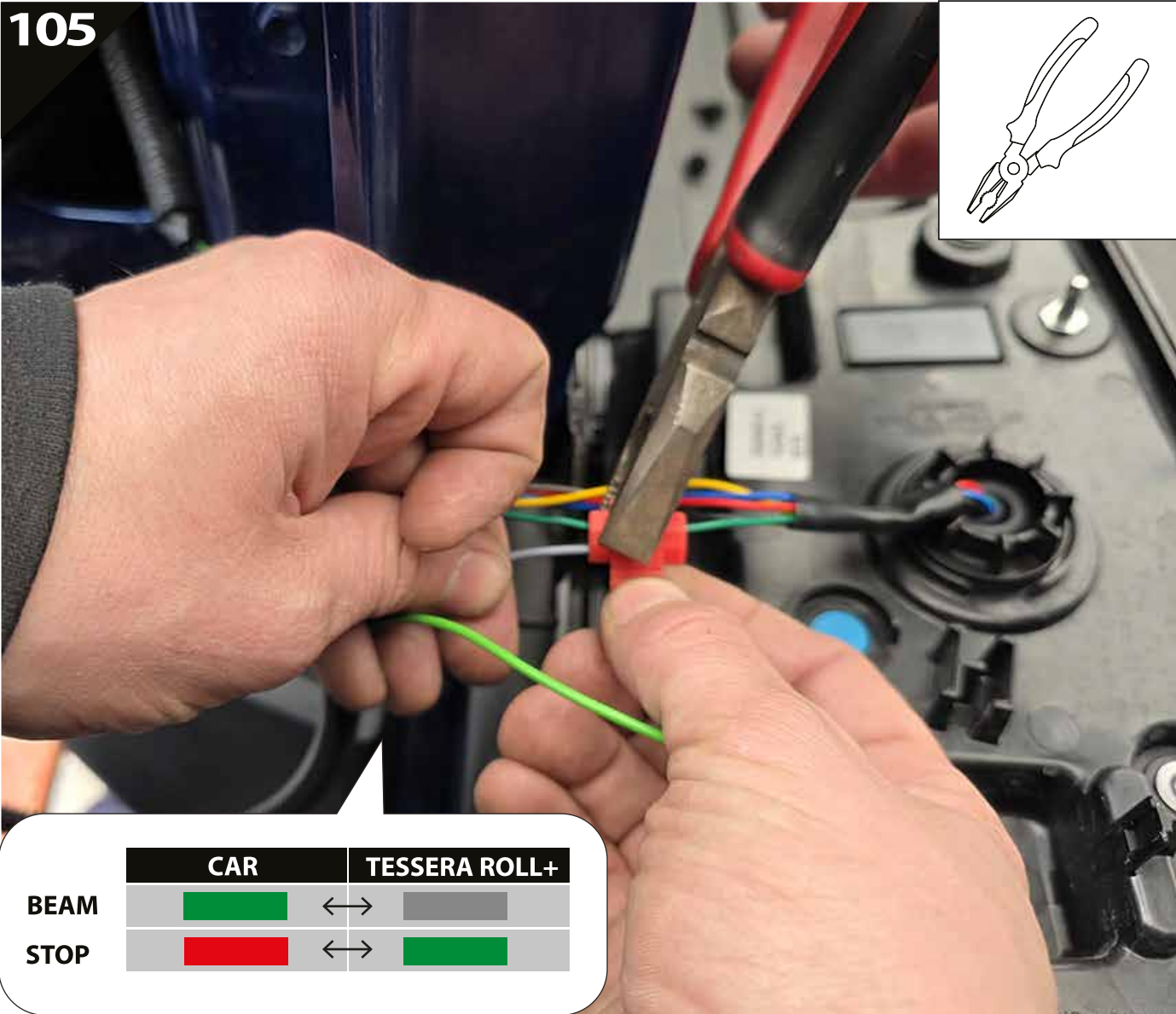
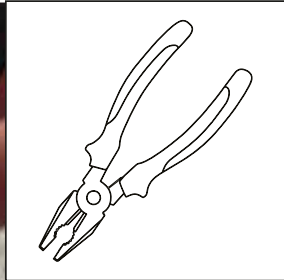

105



	CAR		TESSERA ROLL+
BEAM		↔	
STOP		↔	

106

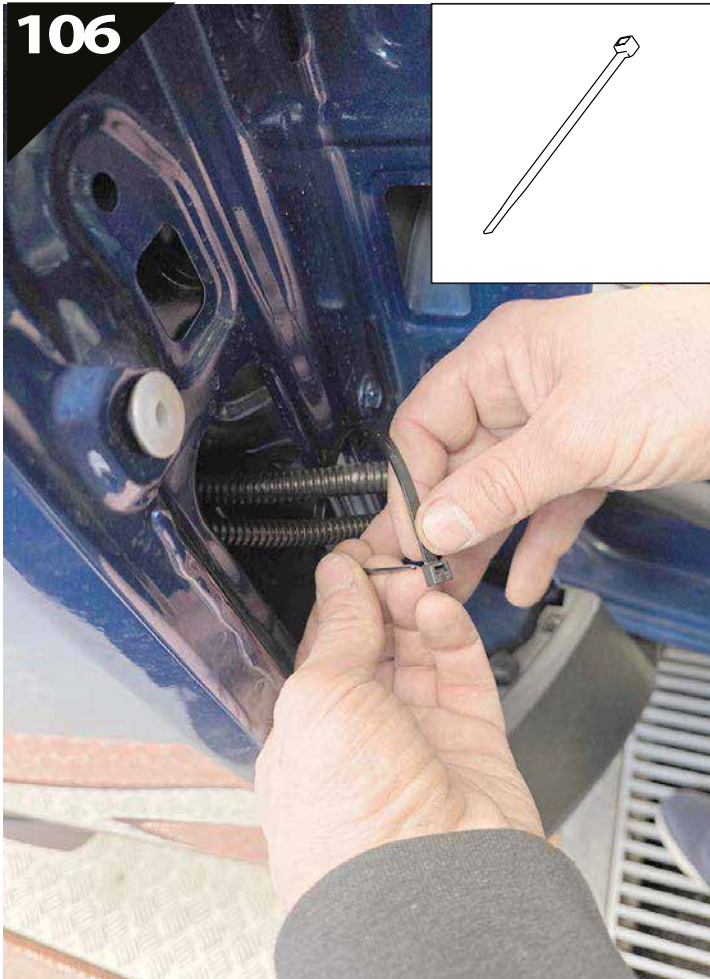

107

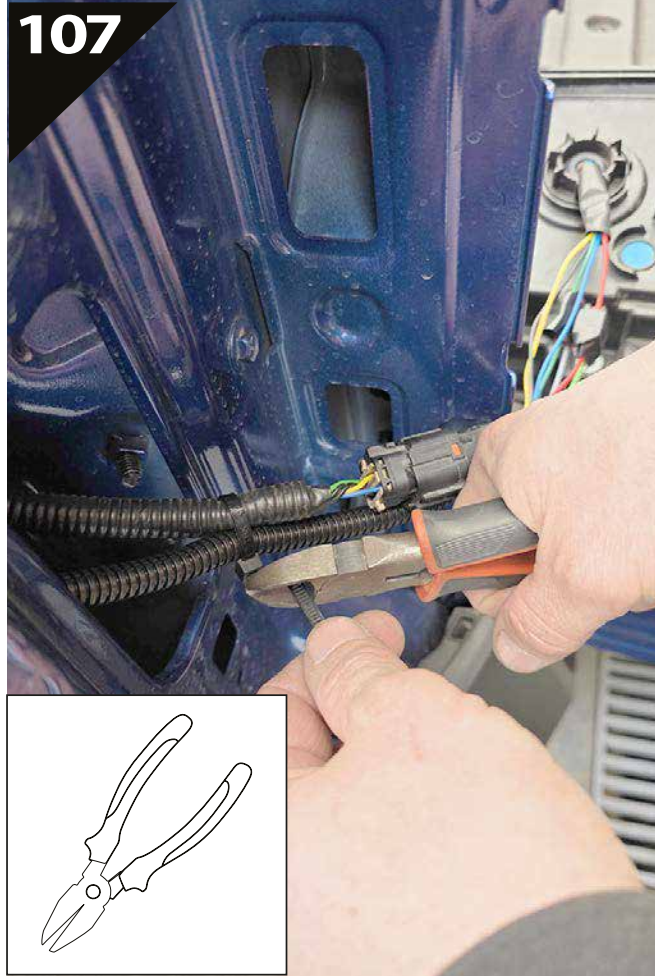

108

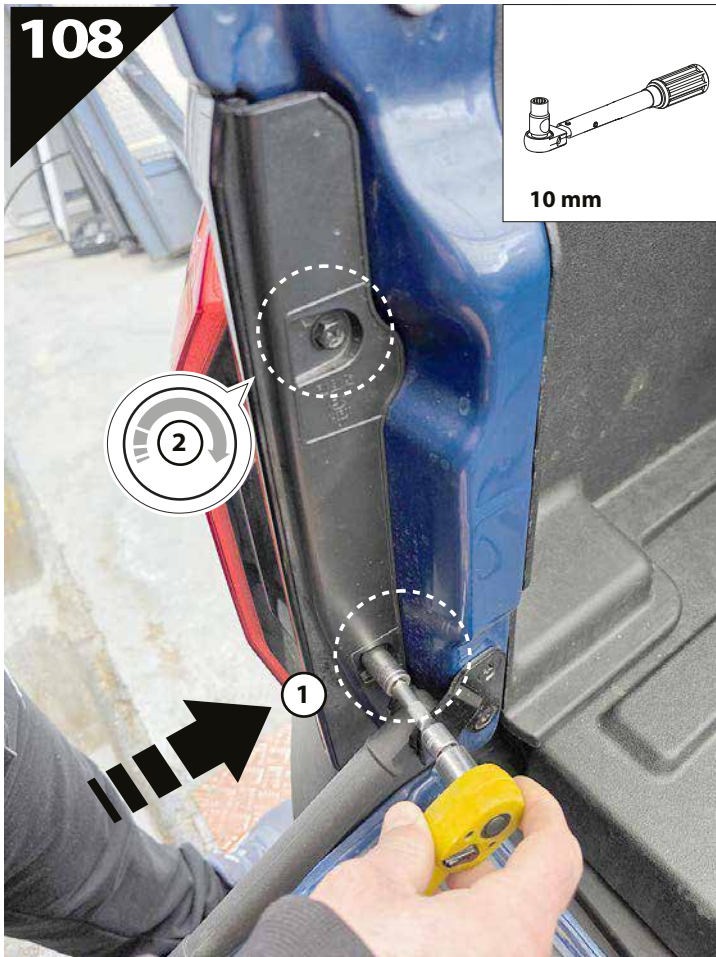

109

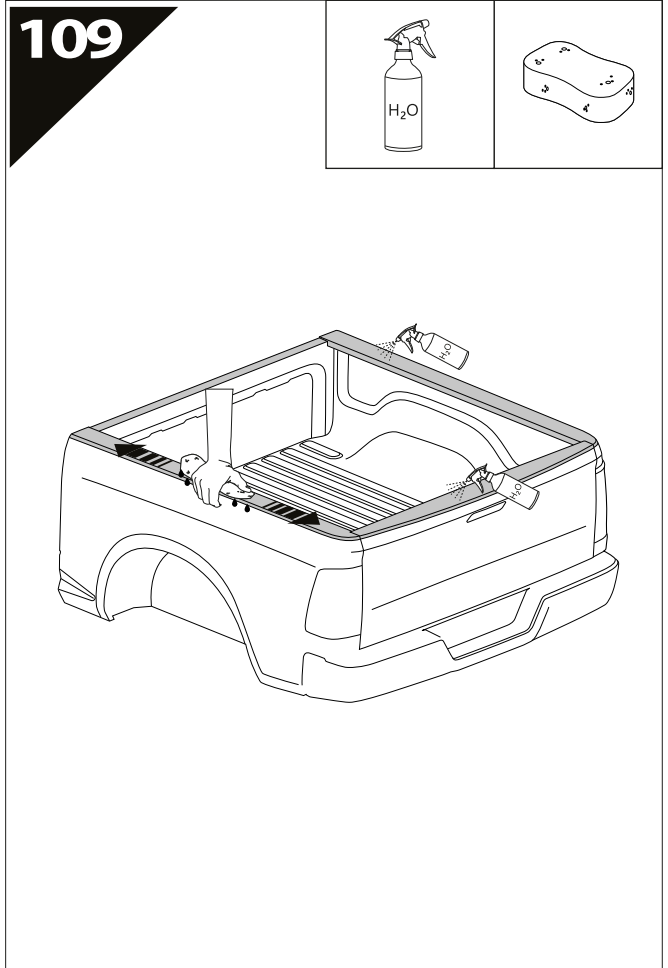

110

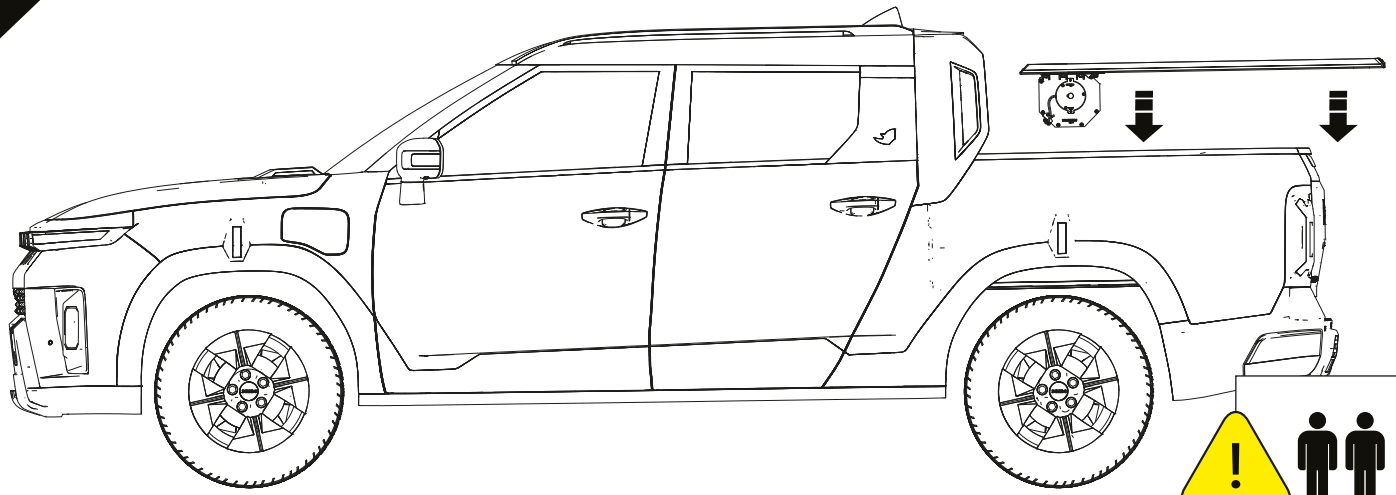

111

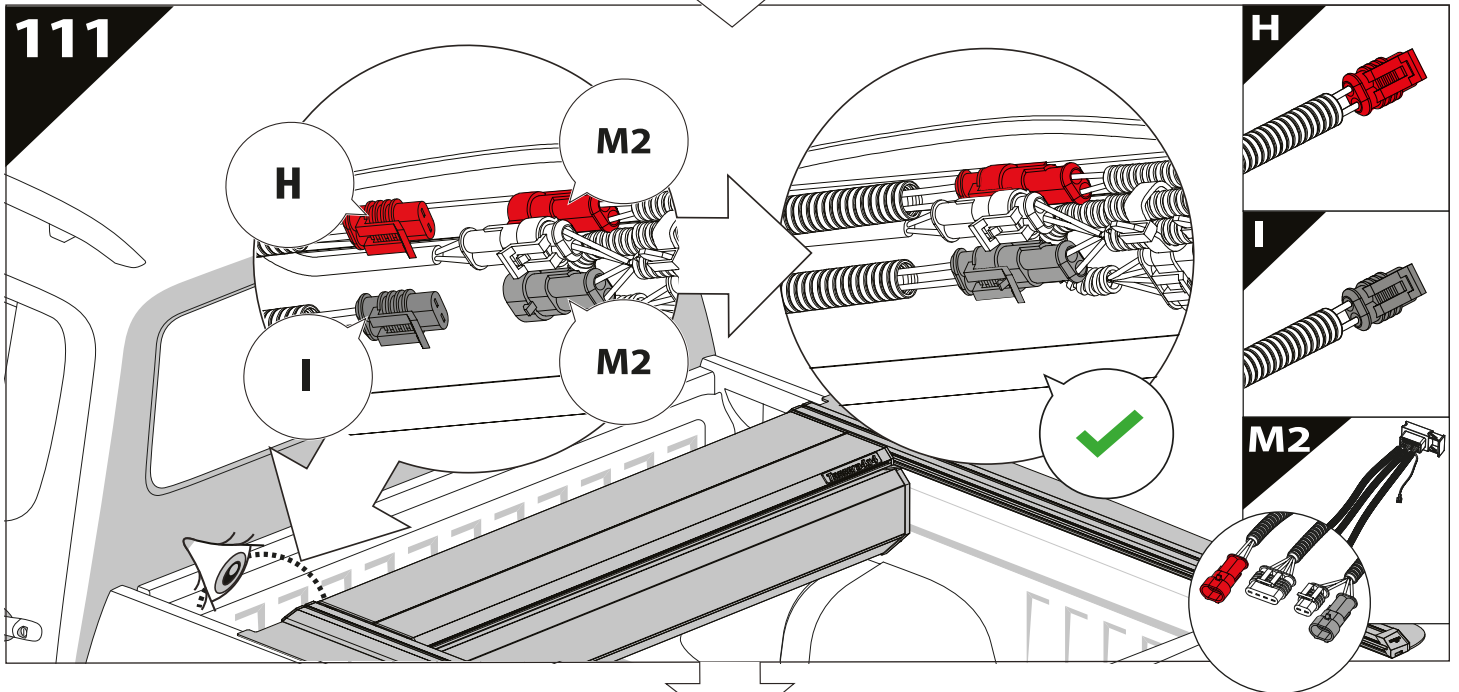

112

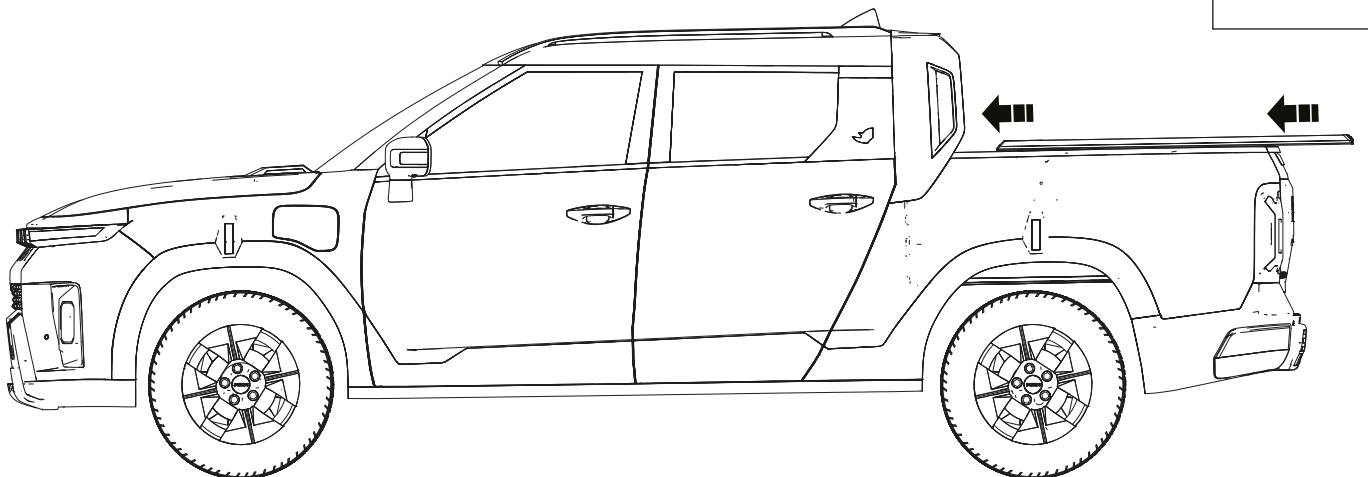



$X = X'$

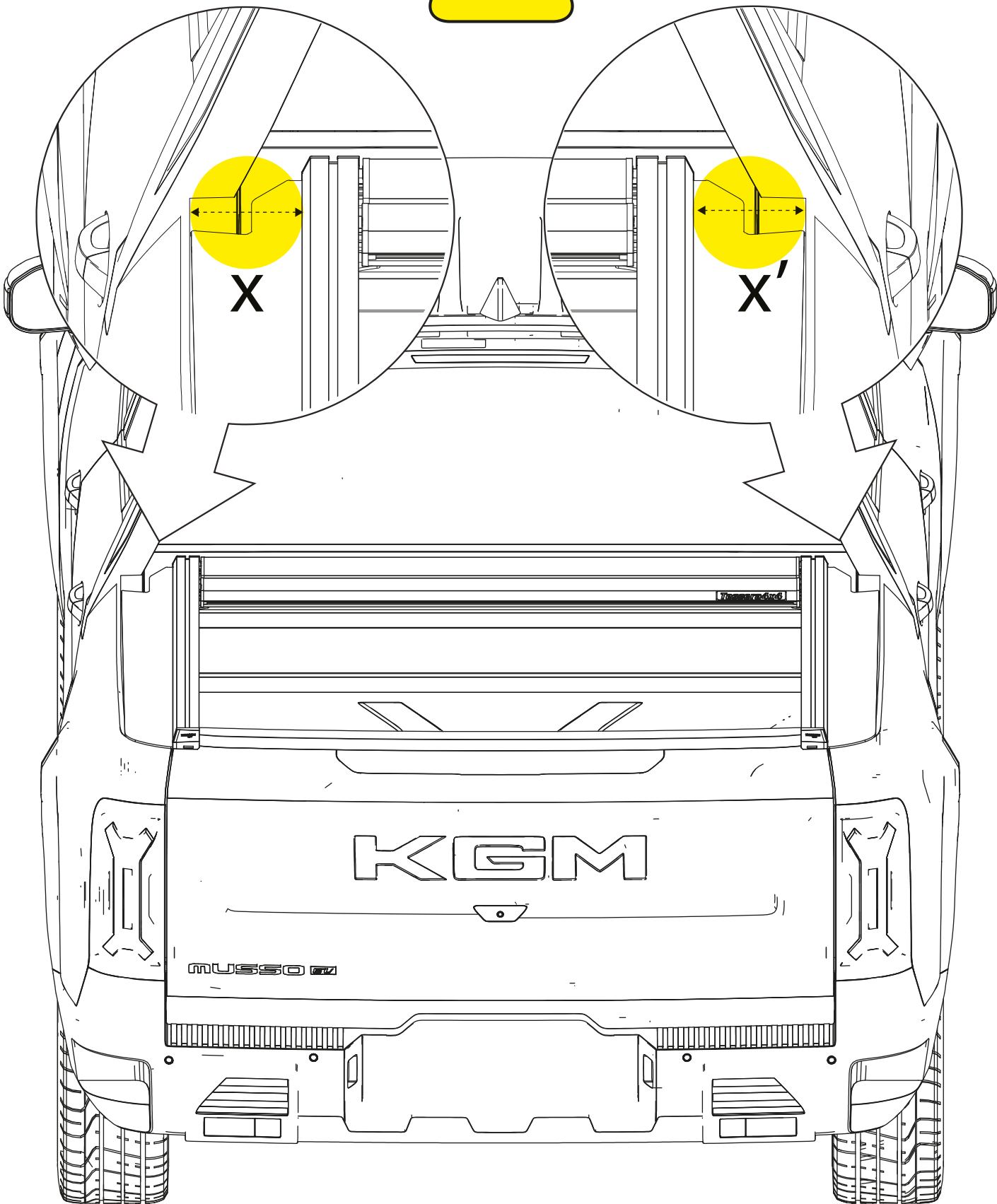

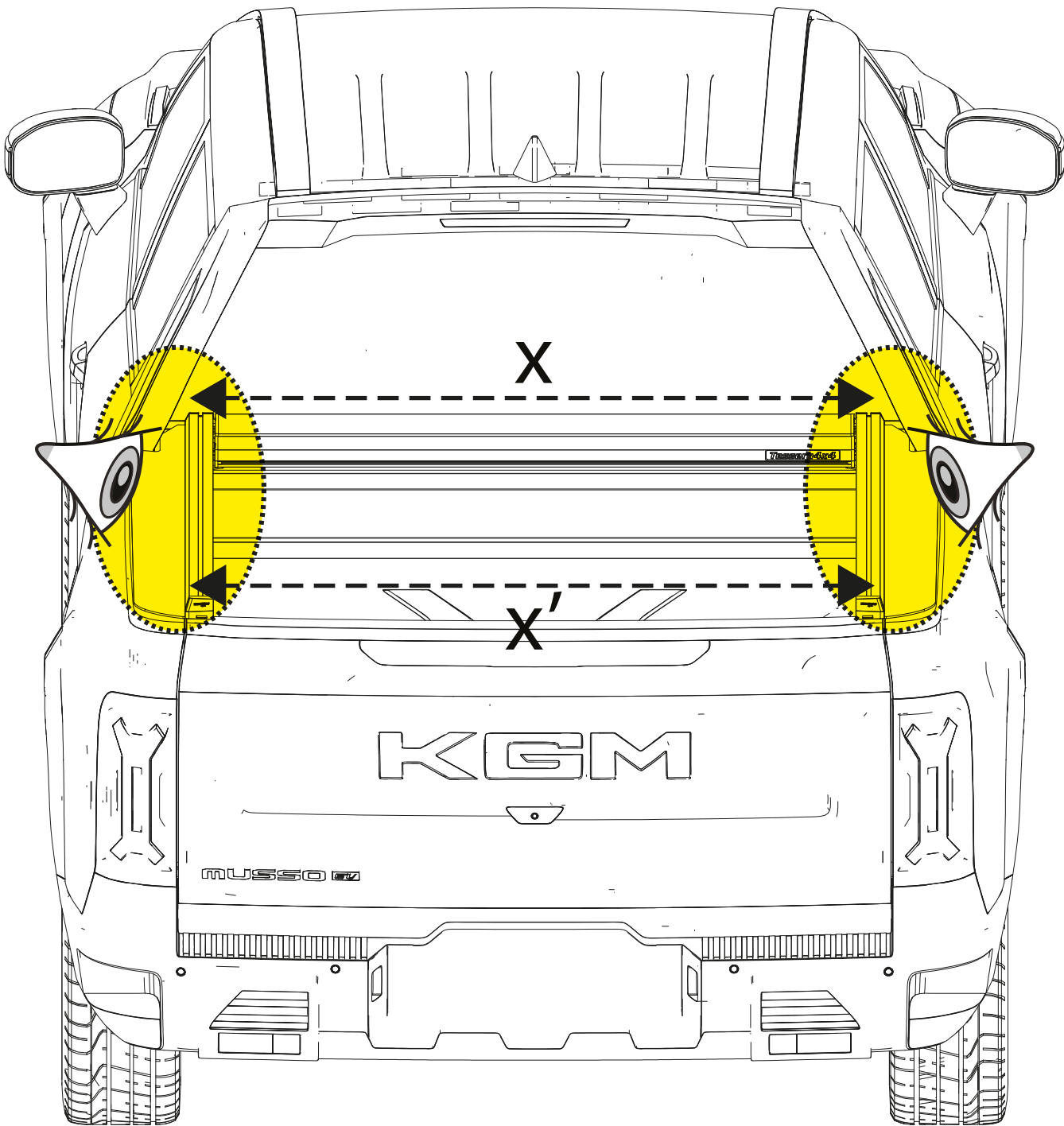
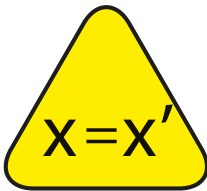

115

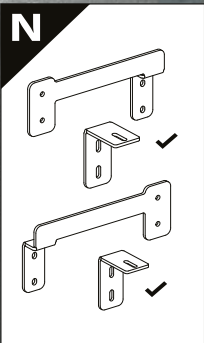
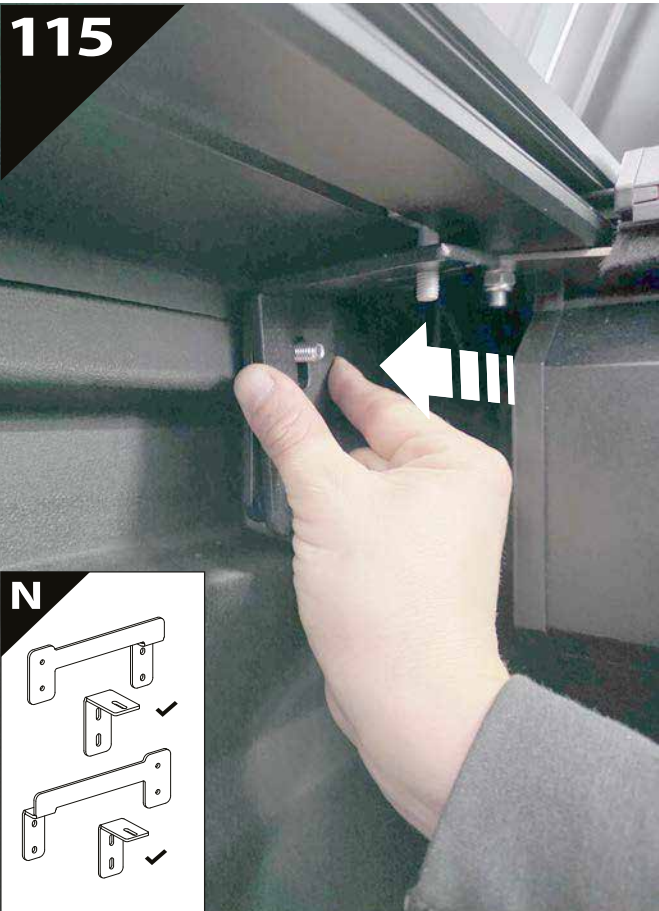

116

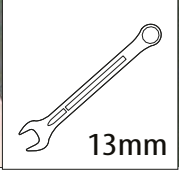
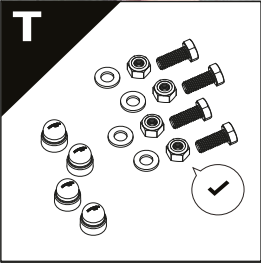
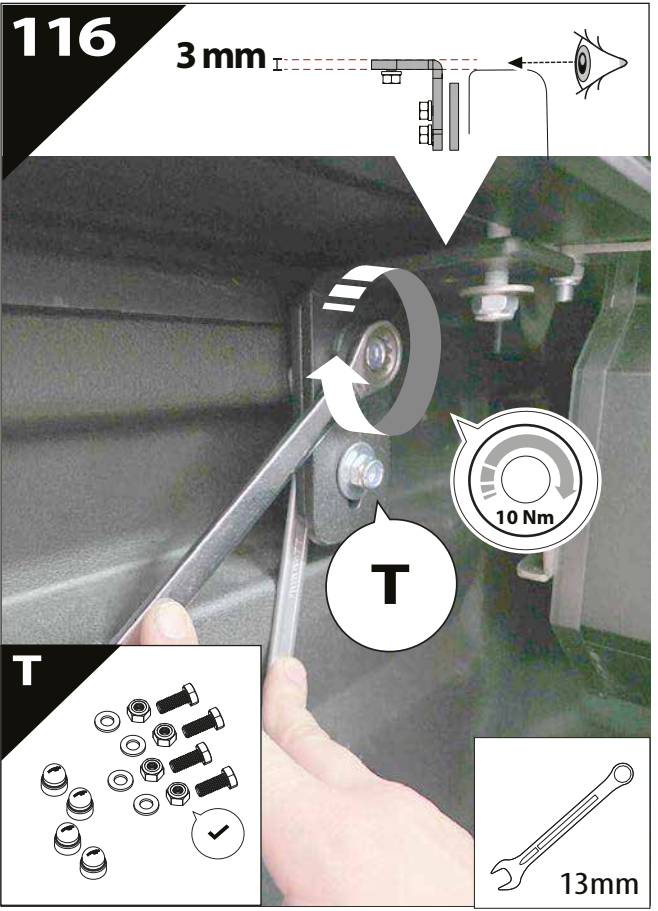

117

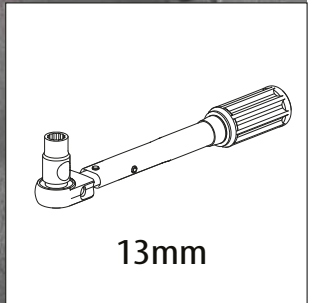
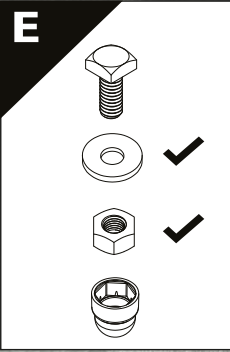
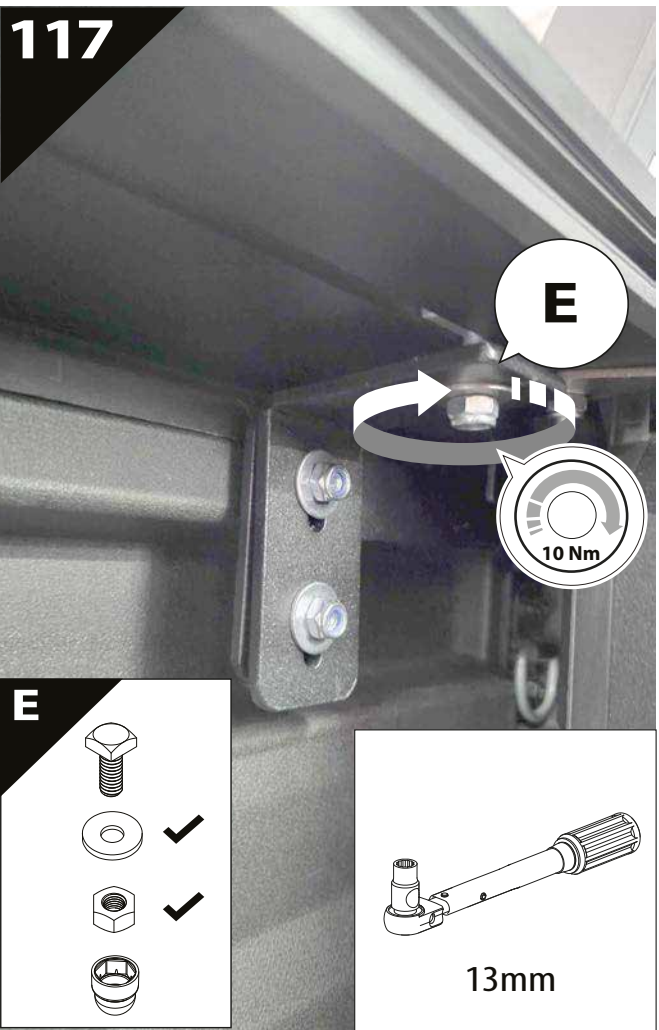

118

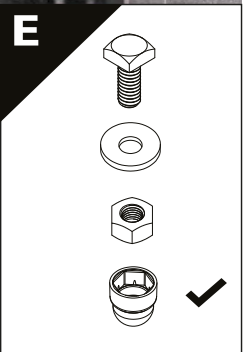
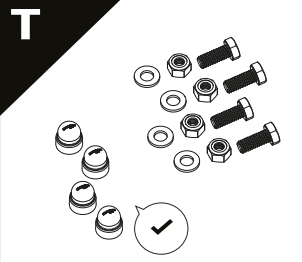
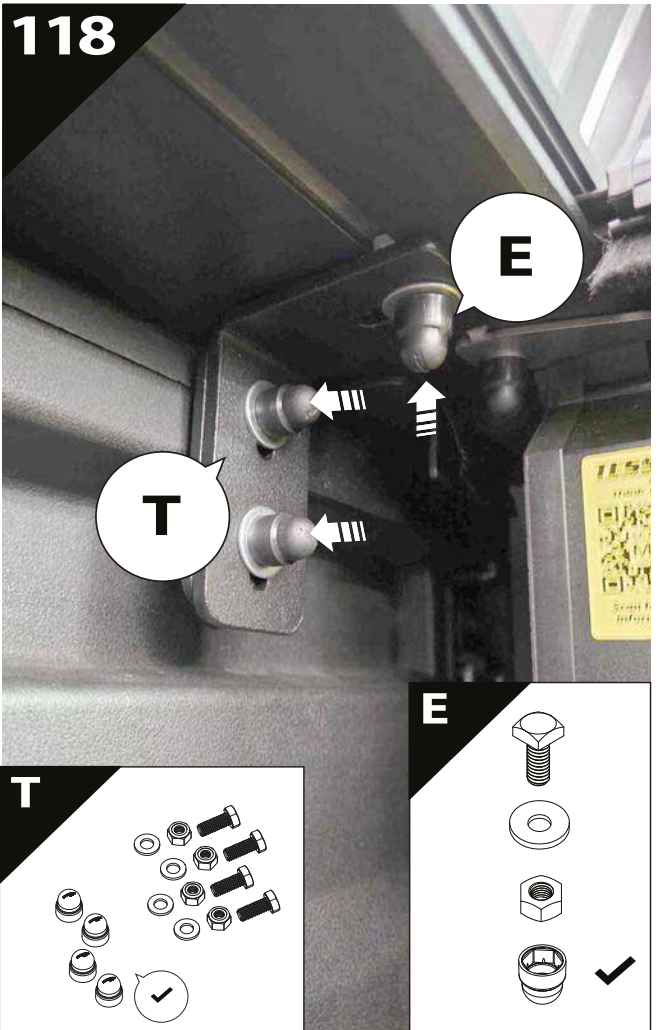

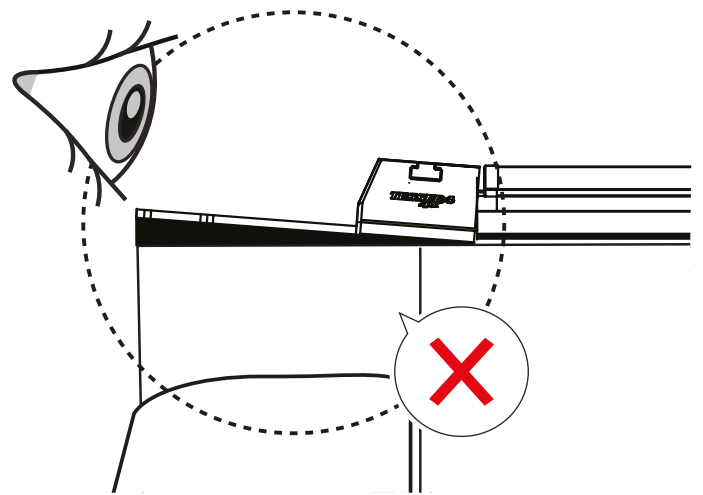
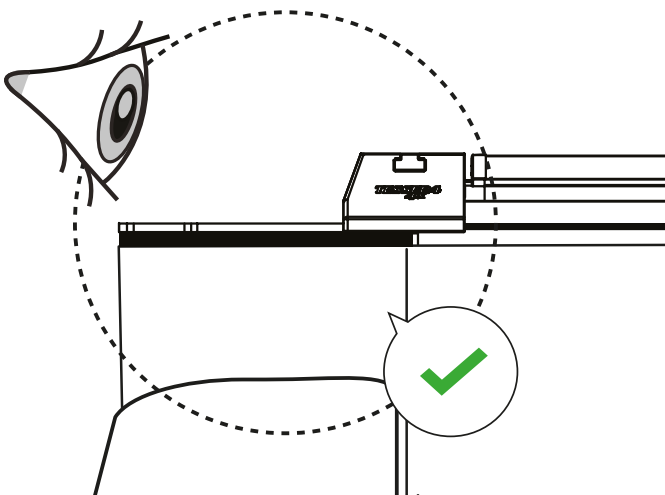
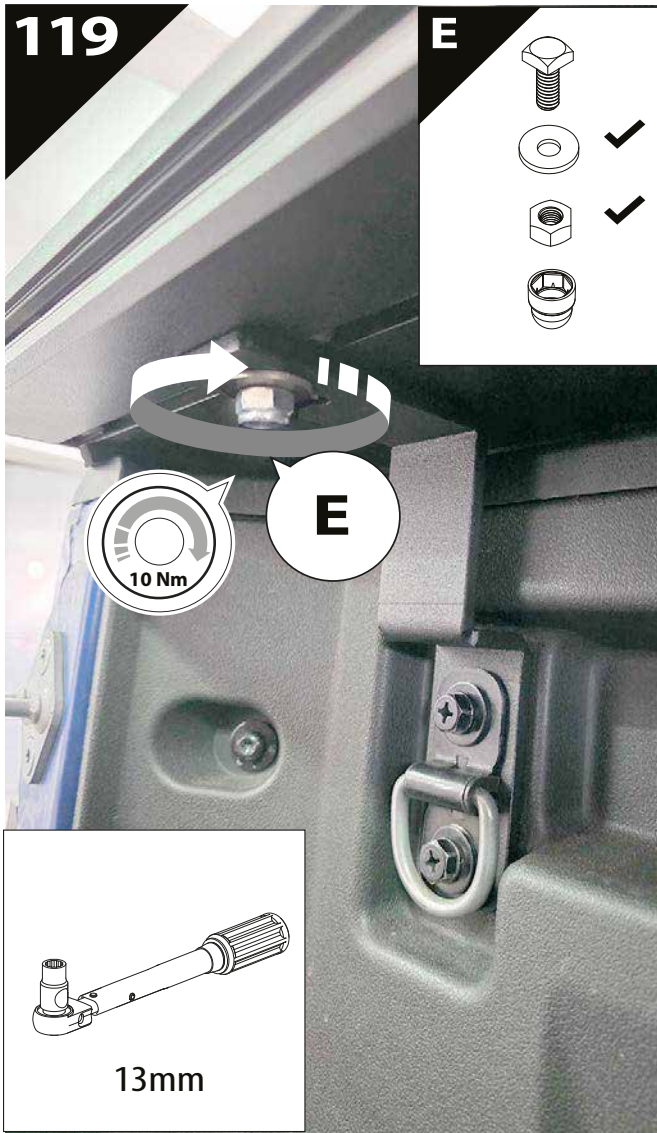

121

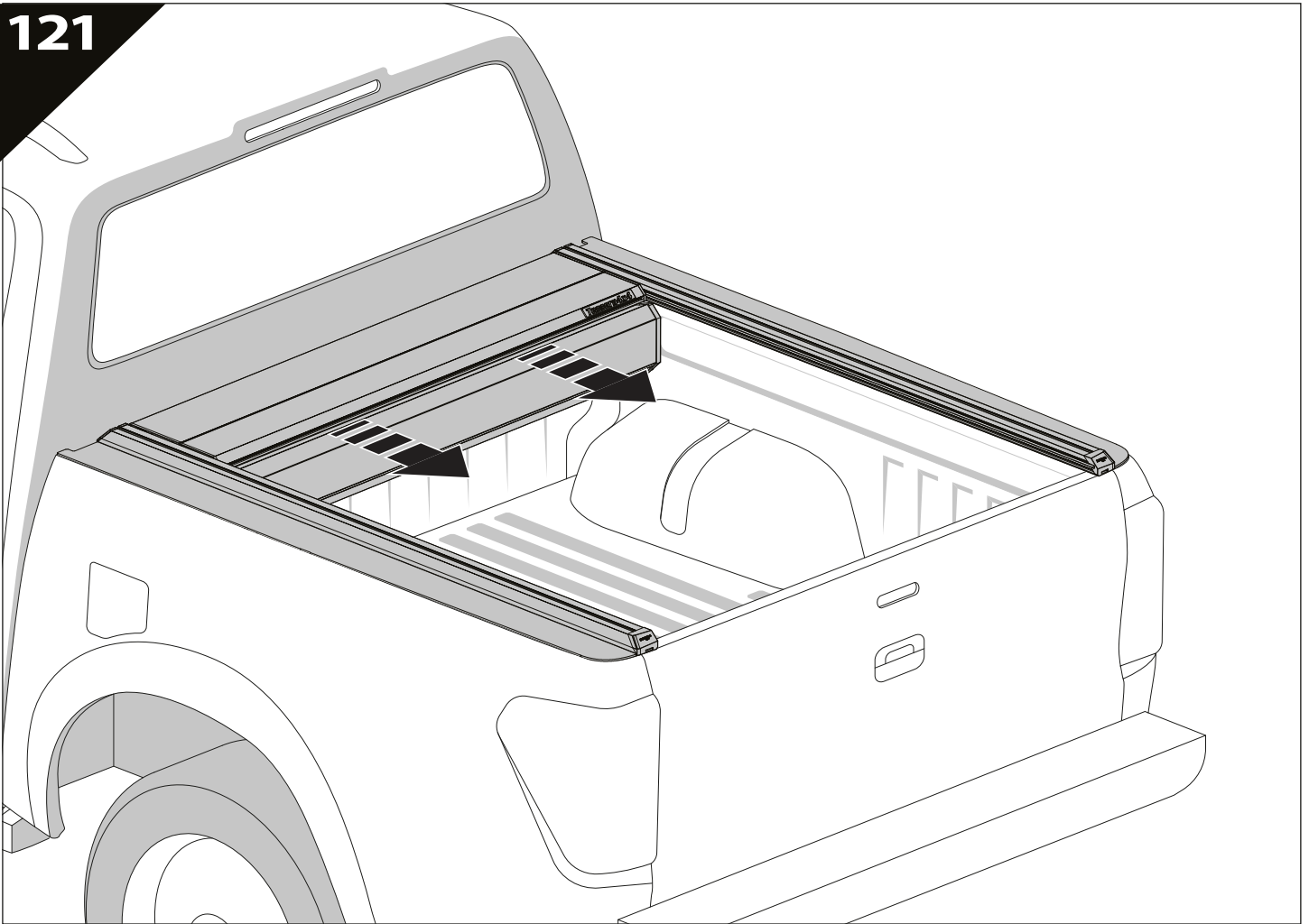

122

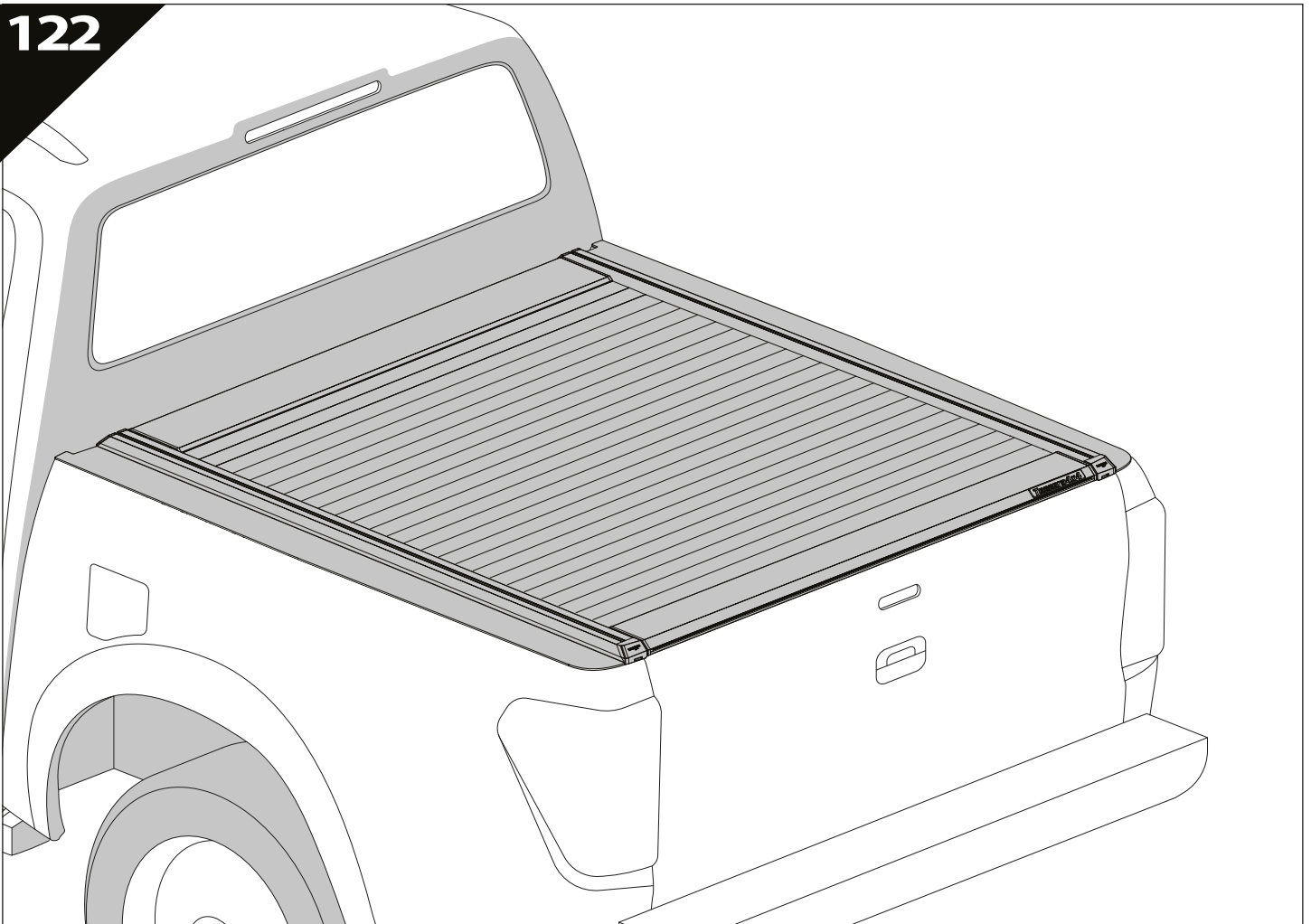









**GR:** Οδηγίες Εγκατάστασης  
**GB:** Installation manual  
**SF:** Asennusohje  
**F:** Notice de montage  
**PL:** Instrukcja montażu  
**NL:** Installatie-instructies  
**TR:** Montaj Talimatı  
**S:** Monteringsanvisning  
**E:** Instrucciones de montaje

**H:** Szerelési utasítás  
**P:** Instruções de instalação  
**RUS:** Инструкция по установке  
**N:** Monteringsveiledning  
**D:** Einbauanleitung  
**CZ:** Návod k instalaci  
**I:** Istruzioni de montaggio  
**DK:** Monteringsvejledning  
**RO:** Instructiuni de instalare

Customer Service:

+30 (210) 5541161, +30 (210) 5541154 (08:00 - 16:00 EET)

Support department:

[info@gianso.gr](mailto:info@gianso.gr)

Website:

[www.tessera4x4.com](http://www.tessera4x4.com)

Address:

19.5 km of National road Athens-Korinthos (Elefsina) Greece, P.C: 19200