

Technical Report No.: 61009 – 26 – TAC
Test method: Regulation UN No. 17
Manufacturer / Order party: Audrio Kručiaus i.i.
Product under test: Swivel plate - type AS



**TECHNICAL REPORT
No. 61009 – 26 – TAC**

Test according to

Regulation UN No. 17

Road vehicles - Securing of cargo in passenger cars, station wagons and multi-purpose vehicles - Requirements and test methods

Test method: Regulation UN No. 17.00 of 1970-12-01
including all amendments up to and including:
Regulation UN No. 17.10, supplement 0 – date of entry into force: 2021-06-09

Objectives: On the manufacturers request

I. Technical data

- 0.1.1. Order party: Audrio Kručiaus i.i.
Ekskavatorininkų 7-6 Kaunas
52369 LITHUANIA
- 0.1.2. Manufacturer: Audrio Kručiaus i.i.
Ekskavatorininkų 7-6 Kaunas
52369 LITHUANIA
- 0.2. Product under test: Swivel plate - type AS
- 0.3. Test required: Acceleration sled test according to Regulation
UN No. 17, paragraph 6.3

II. Test report

1. Test conditions

- 1.1. Test sample: Swivel plate - type AS
- 1.1.1. Technical data from the manufacturer: According to IV. Attachments:
Maximum mass of the swivel plate 16 kg
Maximum mass of original seat with base 43kg
For list of dedicated vehicles see Attachment



Technical Report No.: 61009 – 26 – TAC
 Test method: Regulation UN No. 17
 Manufacturer / Order party: Audrio Kručias i.i.
 Product under test: Swivel plate - type AS

2/7

- 1.2. Test procedures used: Acceleration dynamic test according to Regulation UN No. 17.10, paragraph 6.3
- 1.3. Measuring and test equipment: sled test rig and propulsion system IST CSA Advanced ZZ-421
 - accelerometer: (PM-3625)
 - datalogger: KiDAU (PM-2746)
 - 3DH machine (PM-0935)
- 1.4. Testing conditions: 61009-26-TAC_01: 21,3 °C
- 1.5. Test track or site: TÜV SÜD Czech s.r.o.,
 Bezděčín,
 Czech Republic

2. Test result

2.1. Seat adjustment

	Frontal crash seat	Rear crash seat
Torso angle	25°	25°
Longitudinal adjustment	1 st notch from front most	1 st notch from rear most
Vertical adjustment	Upwards	Upwards
Head restraint	Upwards	Upwards

Seat adjustment for each crash direction set up by laboratory as a worst case.

2.1.1.3 Test speed and achieved acceleration

	Requirement	Measured
Impact speed v_0	50 ⁺⁰ -2 km/h	49,25
Acceleration	Acc. to Annex 9	OK

Technical Report No.: 61009 – 26 – TAC
Test method: Regulation UN No. 17
Manufacturer / Order party: Audrio Kručias i.i.
Product under test: Swivel plate - type AS



2.5 Test result

During and after test:

- There was no failure of the seat frame or seat anchorage, adjustment and displacement systems or their locking devices during the test
- There was no release of the locking systems during the tests

Technical Report No.: 61009 – 26 – TAC
Test method: Regulation UN No. 17
Manufacturer / Order party: Audrio Kručias i.i.
Product under test: Swivel plate - type AS



4/7

3. Specimen submitted to test on: 2026-01-29

4. Date of test: 2026-02-06

III. Other documentation

Photos: pages 5 - 6
Graphs: page 7

IV. Attachments

Attachment No. 1: No. of pages: 16

Measuring and test equipment and test site meet the requirements of the applicable legislation. This report shall never be reproduced incomplete and without a written permission of the testing laboratory (except for use in the type-approval or approval documentation). A decision rule (in the section Final assessment) without consideration of measurement uncertainties is used for statement of conformity.

V. Final assessment

The described sample in tested items **complies**
with the requirements of Regulation UN No. 17.10, paragraph 6.3

This technical report consists of pages No. 1 to 7 and 16 pages of attachments.

Test report approved by

Radek Čeřovský

Report author

Filip Novotný

Profit center manager

Prague, 2026-02-23

Technical Report No.: 61009 – 26 – TAC
Test method: Regulation UN No. 17
Manufacturer / Order party: Audrio Kručias i.i.
Product under test: Swivel plate - type AS



Photos:

Test No. 61009-26-TAC_01

Photos PRE test



Technical Report No.: 61009 – 26 – TAC
Test method: Regulation UN No. 17
Manufacturer / Order party: Audrio Kručias i.i.
Product under test: Swivel plate - type AS

Test No. 61009-26-TAC_01
Photos POST test





Technical Report No.: 61009 – 26 – TAC
 Test method: Regulation UN No. 17
 Manufacturer / Order party: Audrio Kručias i.i.
 Product under test: Swivel plate - type AS

Graphs:

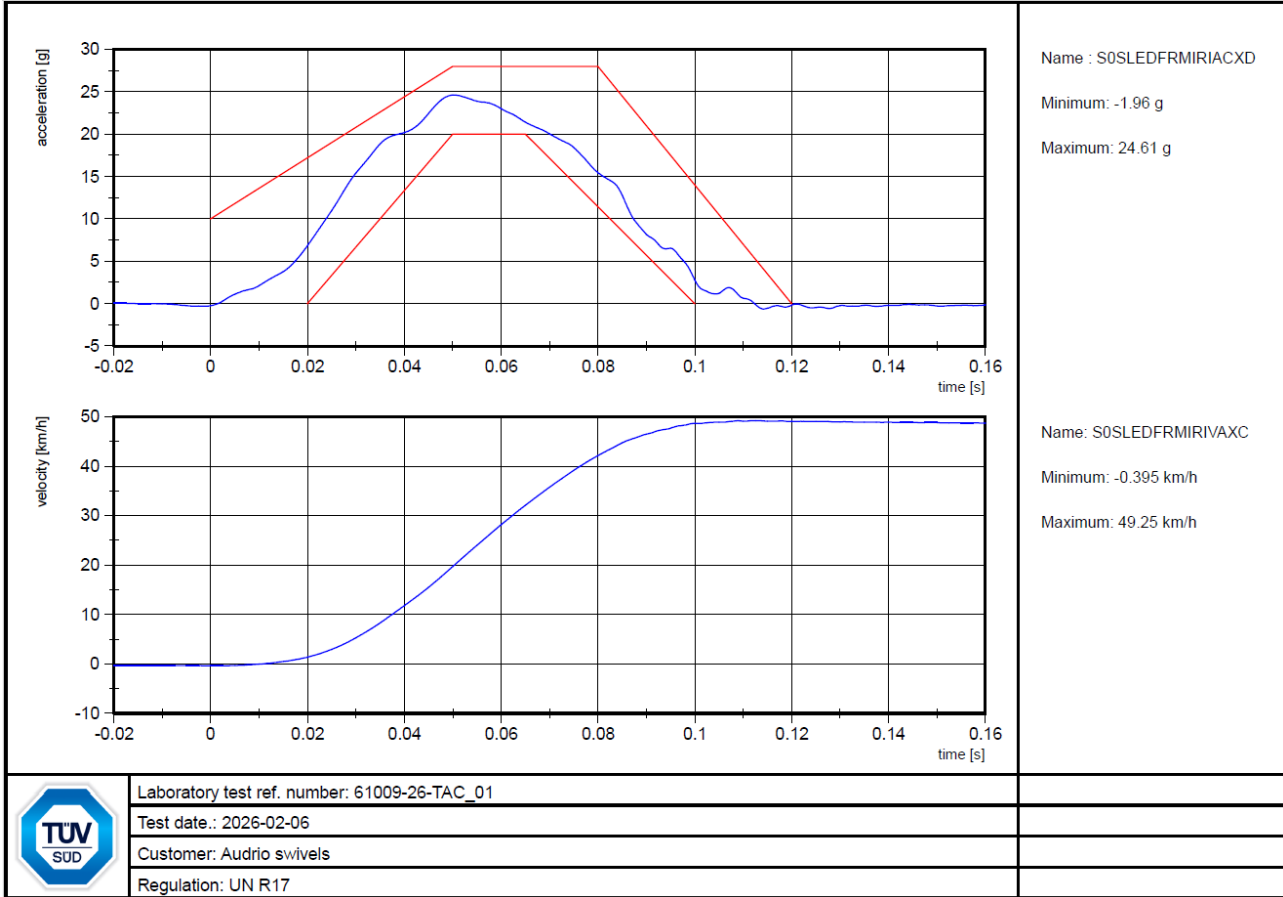

End of the technical report



INFORMATION FOLDER / DOCUMENT:

AUDRIOSWIVELS/01/2026-00

PURSUANT TO UN/ECE REGULATIONS
No. 14-09
"UNIFORM PROVISIONS CONCERNING THE APPROVAL OF VEHICLES WITH
REGARD TO SAFETY-BELT ANCHORAGES"

FOR THE SEATS EQUIPPED WITH SWIVEL AUDRIOSWIVELS
TYPE S

No. 17-09
"UNIFORM PROVISIONS CONCERNING THE APPROVAL OF VEHICLES WITH
REGARD TO THE SEATS, THEIR ANCHORAGES AND ANY HEAD RESTRAINTS"

FOR THE SEATS EQUIPPED WITH SWIVEL AUDRIOSWIVELS
TYPE S

.....
Company owner Audrys Kručius

Total number of pages 16

Date of issue 10.01.2026

		Date:10.01.2026
	AUDRIOSWIVELS 01/2056-00	Page/pages:1/16



List of documentation and supplements

Confirmation.....	3
0. General.....	4
1. General construction characteristics of the vehicle.....	5
9. Bodywork.....	5

List of enclosures

Table of vehicles types	Enclosure 1
Seats and seat belt anchorages	Enclosure 2
Seat anchorages	Enclosure 3

		Date:10.01.2026
	AUDRIOSWIVELS 01/2056-00	Page/pages:2/16



Confirmation

We hereby declare that the vehicle specimens submitted for this approval test have been manufactured and assembled on conditions of ordinary mass production and that they are compatible with the enclosed documentation.

Date of issue:10 January 2026

.....
Audrys Kručius
Company Owner

A		Date:10.01.2026
	AUDRIOSWIVELS 01/2056-00	Page/pages:3/16



0. GENERAL

0,1 Make (trade name) : AUDRIOSWIVELS

0.2. Type: AS

Variant/Version

AS-?

"?"-Dedicated for the vehicles:

S - Mercedes-Benz Sprinter 906,
Volkswagen Crafter 2E???,
Freightliner/Dodge Sprinter

V - Mercedes-Benz Sprinter 907,
Sprinter910, Freightliner/Dodge
Sprinter

C - Volkswagen Crafter, MAN TGE

A - Volkswagen T5, Volkswagen T6

F - Fiat Ducato, Peugeot Boxer,
Citroen Jumper, RAM ProMaster

0.2.1 Dedicated for vehicle(s) See Enclosure 1

0.4 Category of vehicle: M1, N1, M2, N2

0.5. Name and address of manufacturer
Audrio Kručiaus ind.įmonė
Ekskavatorininkų 7-6 Kaunas
52369 LITHUANIA

		Date:10.01.2026
	AUDRIOSWIVELS 01/2056-00	Page/pages:4/16

1, GENERAL CONSTRUCTION CHARACTERISTICS OF THE VEHICLE

1.1 Details of a representative vehicle: See base vehicle approvals listed in Enclosure 2

9. BODYWORK

9.1 Type of bodywork using the codes AC,AF, BB, BX, CA, SA, SH set out in Part C of Annex1 of Directive 2007/46/EC on in Part C of Annex1 to regulation (EU) 2018/858

9,10. Interior arrangement

9.10.3 Seats

9.10.3.1 Number of setting positions: 1 or2 (Driver and pasenger)

9.10.3.1.1 Location and arrangement: 1st row of seats(idriving cab)

9.10.3.2 Seat(s) designed for use when the vehicle is stationary N/A

9.10.3.3. Mass:
Mass of original driver’s/passenge seat and base with additional swivel AUDRIOSWIVELS AS - 59kg(allowable mass in the heaviest configuration)

Vehicle(s)	Maximum mass of original seat with base	Mass of the swivel plate
MB Sprinter(906), (907), (910) VW Crafter(2E???) Dodge Sprinter	43 kg	16kg
VW Crafter, MAN TGE	42.5kg	15kg
Fiat Ducato CitroenJumper Peugeot Boxer	40,7 kg	
Volkswagen T5-T6	40 kg	

Details - see Enclosures

9.10.3.4	Characteristics: for seats not type-approved as components, description and drawings of	
9.10.3.4.1	The seats and their anchorages:	See base vehicle approvals listed in Enclosure 2 and Enclosure 3
9.10.3.4.2	The displacement and locking systems:	See base vehicle approvals listed in Enclosure 2
9.10.3.4.3	The displacement and locking systems:	See listed base vehicle approvals and description in Enclosure 2
9.10.3.4.4	The seat-belt anchorages (if incorporated in the seat structure):	See base vehicle approvals listed in Enclosure 2
9.10.3.4.5	The parts of the vehicle used as anchorages:	See base vehicle approvals listed in Enclosure 2
9.10.3.5	Coordinates or drawing of the R-point	
9.10.3.5.1	Driver's seat:	See base vehicle approvals listed in Enclosure 2
9.10.3.5.2		See base vehicle approvals listed in Enclosure 2
9.10.3.6	Design torso angle	
9.10.3.6.1	Driver's seat:	See base vehicle approvals listed in Enclosure 2
9.10.3.6.2	All other seating positions:	See base vehicle approvals listed in Enclosure 2
9.10.3.7	Range of seat adjustment	
9.10.3.7.1	Driver's seat:	See base vehicle approvals listed in Enclosure 2
9.10.3.7.2	All other seating positions:	See base vehicle approvals listed in Enclosure 2
9.10.4	Head restraints	
9.10.4.1	Type(s) of head restraints:	See base vehicle approvals listed in Enclosure 2
9.10.4.2	Type-approval numbers), if available:	See base vehicle approvals listed in Enclosure 2
9.10.4.3	For head restraints not yet approved	See base vehicle approvals listed in Enclosure 2

9.13 Safety belt anchorages

9.13.1 Photographs and/or drawings of the dimensions of the actualisation and effective anchorages including the R-points: See base vehicle approvals listed in Enclosure 2 and Enclosure 3

9.13.2 Drawings of the belt anchorages and parts of the vehicle structure where they are attached (with the material indication): See base vehicle approvals listed in Enclosure 2

9.13.3 Designation of the types of safety belt authorised for fitting to the anchorages with which the vehicle is equipped:

	Anchorage location	
	Vehicle structure	Seat structure
First row of seats	See base vehicle approvals listed in Enclosure 2	See base vehicle approvals listed in Enclosure 2

9.13.4 Description of a particular type of safety belt where an anchorage is located in the seat backrest or incorporates an energy dissipating device: See base vehicle approvals listed in Enclosure 2



Enclosure 1: TABLE OF VEHICLES TYPES

Manufacturer	Commercial description / Type	Wheelbase
Daimler / Mercedes-Benz	Sprinter (906, 907)	3250, 3665, 4325
	Sprinter (910)	3259, 3924
	Vito/Viano/N-klasse (639,639/2, 639/4)	3200, 3430
VW	Crafter(2 E _)	3250, 3665, 4325
	Crafter (SYN e.g. SYN1E, SYN2E, SYN2Z)	3640, 4490
	WW T5 (7H_, 7E_, 7J_)	3000, 3400
	T6, T6.1 (7H_, 7E_, 7J_)	3000, 3400
Citroen Peugeot Fiat	Jumper (Y)	3000, 3450, 4035
	Boxer (Y)	3000, 3450, 4035
	Ducato (250)	3000, 3450, 4035
MAN	TGE (SYN _ e.g. SYNIE, SYNE, SYN2Z)	3640, 4490
Freightliner/ Dodge	Sprinter	3250, 3665, 4325
RAM	ProMaster	3000, 3450, 4035

A		Date:10.01.2026
	AUDRIOSWIVELS 01/2056-00	Page/pages:8/16

Enclosure 2: SEATS AND SEATBELTS ANCHORAGES

Driver's and single passenger seat is equipped with additional swivel, which allows to lock the seat in forward- or rearward-facing direction (180 degrees). Swivel is mounted between original driver's/passenger seat and seat base. Details of seat and base construction in type approvals according to ECE R14 and ECE R17 presented in table below.

Vehicle(-s)	Number of type approval according to (1st stage of production)		Max mass of original driver's/ passenger seat with base
	ECE R14	ECE R17	
MB Sprinter (906) Volkswagen Crafter (2E???) MB Sprinter (907) MB Sprinter (910) (Freightliner/Dodge Sprinter)	E1 14R-07 0516 E1 14R-07 0524 E1 14R07/08 0832 E1 14R07/08 0832	E1 17RA-08 0530 E1 17RA-08 0546 E1 17R08/04 0982 E1 17R08/04 0982	50 kg
Volkswagen Crafter MAN TGE	E4 14R-07 0735 E4 14R 070740	E4 17RA-08 0653 E4 17RA 080659	49.8 kg
Fiat Ducato Citroën Jumper Peugeot Boxer (Ram ProMaster)	E3 14R-07 3133 E3 14R07 2047 E3 14R07 2046	E3 17RA-08 2953 E3 17RA08 2053 E3 17RA08 2052	40.7 kg
Volkswagen T5 Volkswagen T6	E4 14R 070097	E4 17RA 080112	40kg

Swivel can be locked only in forward-facing direction when the vehicle is in motion and in forward- or rearward-facing direction when the vehicle is stationary.
Anchorage points of seat base to the vehicle floor are the same both before and after swivel installation.

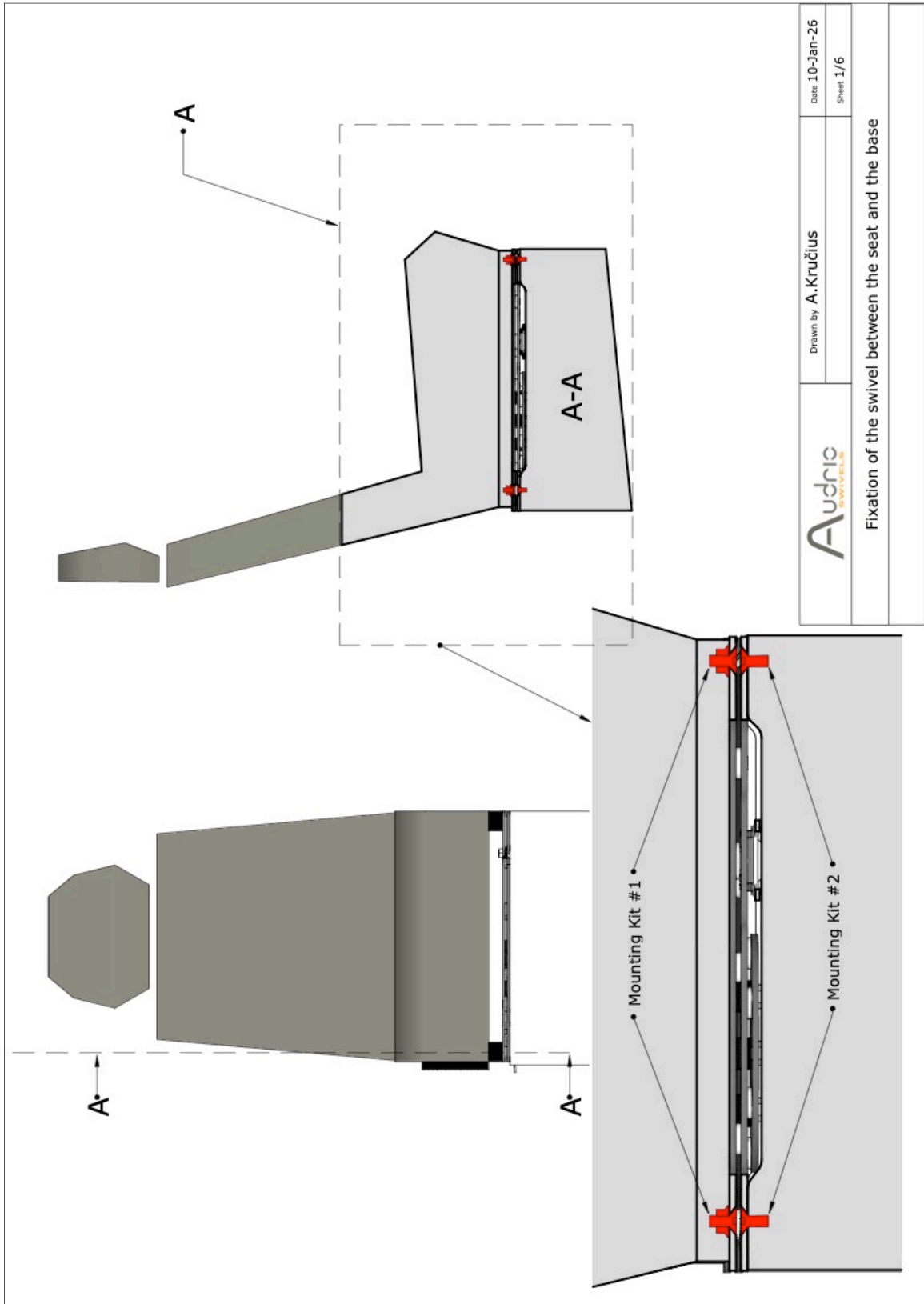

	Drawn by A. Kručius	Date 10-Jan-26
		Sheet 1/6
Fixation of the swivel between the seat and the base		

VEHICLE	MOUNTING KIT #1	MOUNTING KIT #2
MB Sprinter w906 MB Sprinter w907 VW Crafter 2E###	4x DIN 7991 Bolt M10x20-10.9 4x DIN985 Self-locking nut M10	4x DIN 7991 Bolt M10x25-10.9
VW Crafter MAN TGE	4x DIN 7380 Bolt M10x16-10.9 4x DIN 127 Spring Washer M10	4x DIN 7991 Bolt M10x25-10.9
VW T5-T6	4x DIN 7991 Bolt M8x25-10.9 4x DIN985 Self-locking nut M8	4x DIN 7991 Bolt M8x25-10.9
FIAT Ducato CITROEN Jumper PEUGEOT Boxer	6x DIN 7991 Bolt M8x25-10.9 6x DIN985 Self-locking nut M8	6x DIN 7991 Bolt M8x25-10.9

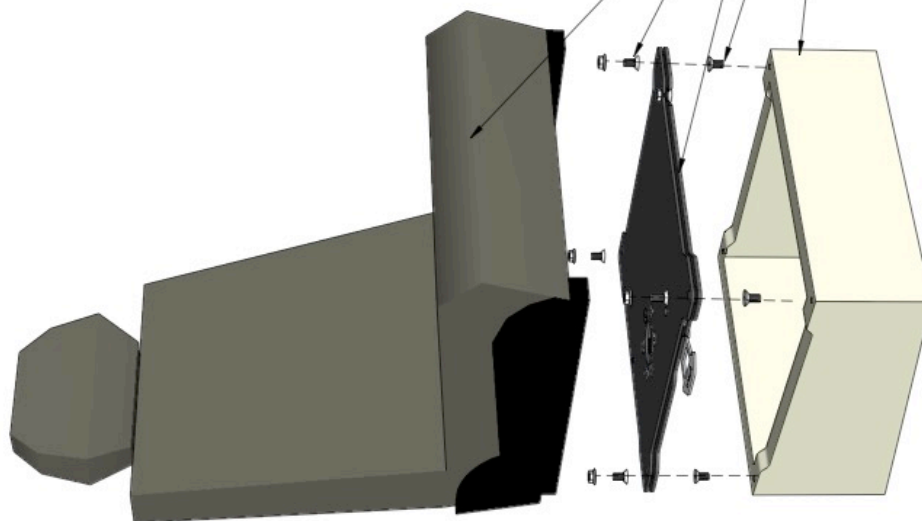

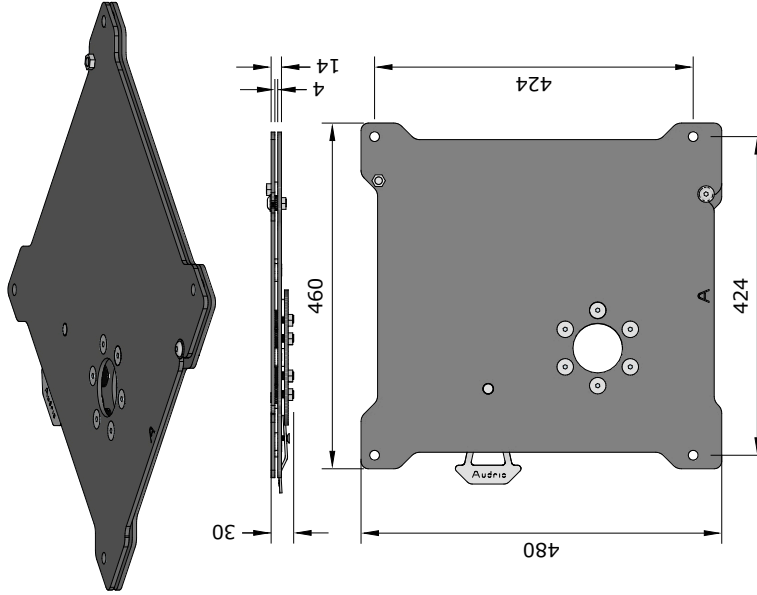

	Drawn by A. Kručius	Date 10-Jan-26
	Approved by	Sheet 1/7
Fixation of the swivel between the seat and the base		

Passenger seat swivel

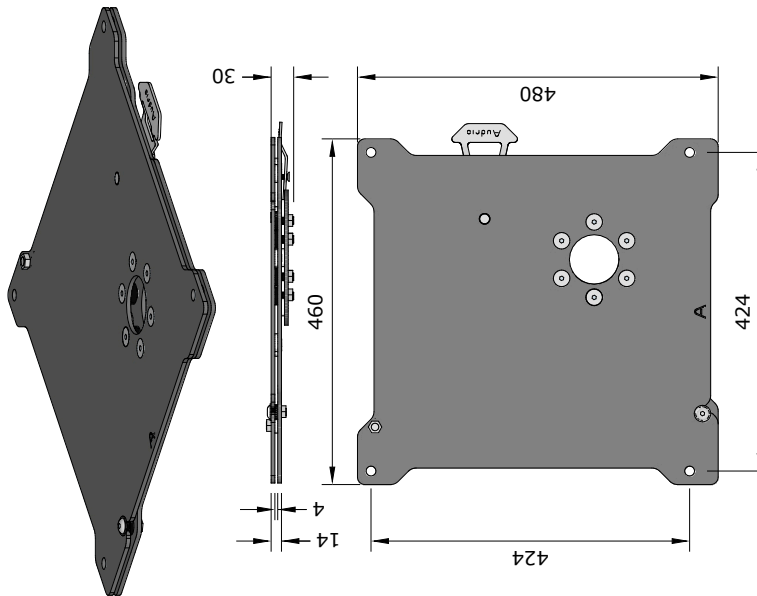

Driverer's seat swivel



	Drawn by A. Kručius	Date 10-Jan-26
		Sheet 1/1
Driver and passenger swivel for MB Sprinter W906, VW Crafter 2E##		

Passenger seat swivel

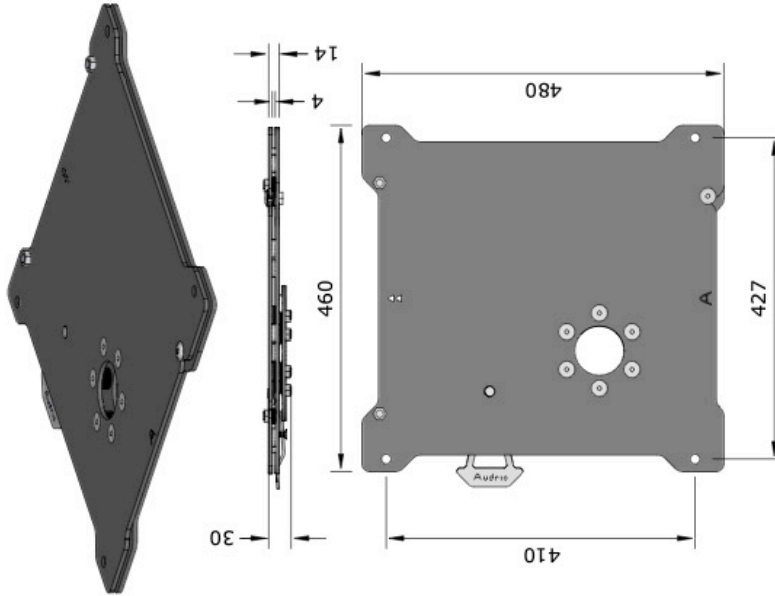

Driverer's seat swivel

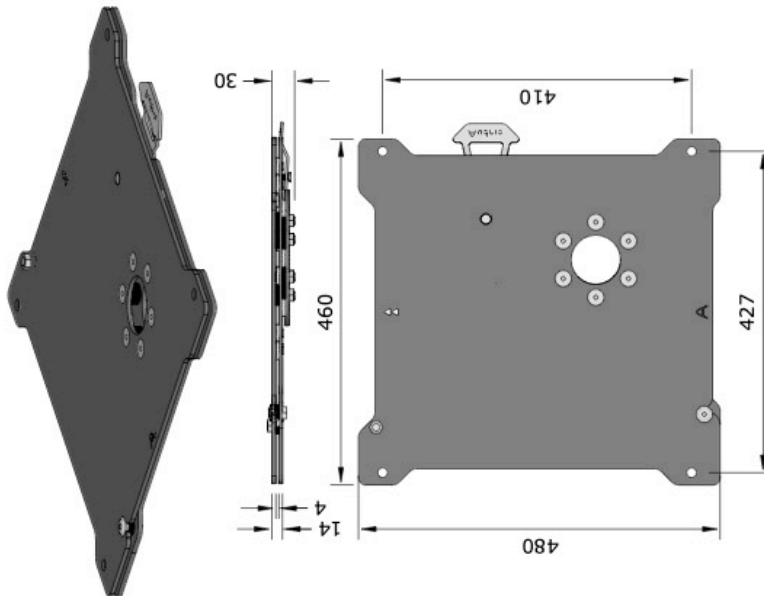

	Drawn by A.Kručius	Date 10-May-24
		Sheet 1/2
Driver's and passenger swivel for MB Sprinter W907 Susp.seat		

Passenger seat swivel

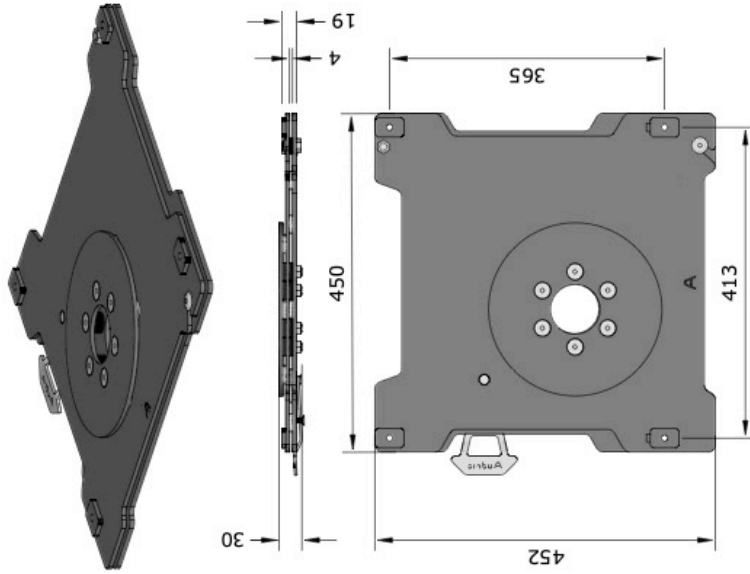

Driver's seat swivel

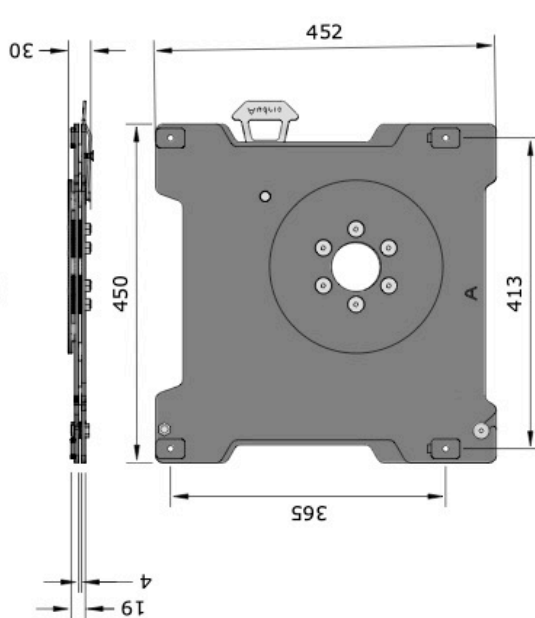

Audric SWIVELS	Drawn by A. Krucius	Date 10-Jan-26
		Sheet 1/3
Driver's and passenger swivel for VW Crafter/MAN TGE		

Passenger seat swivel

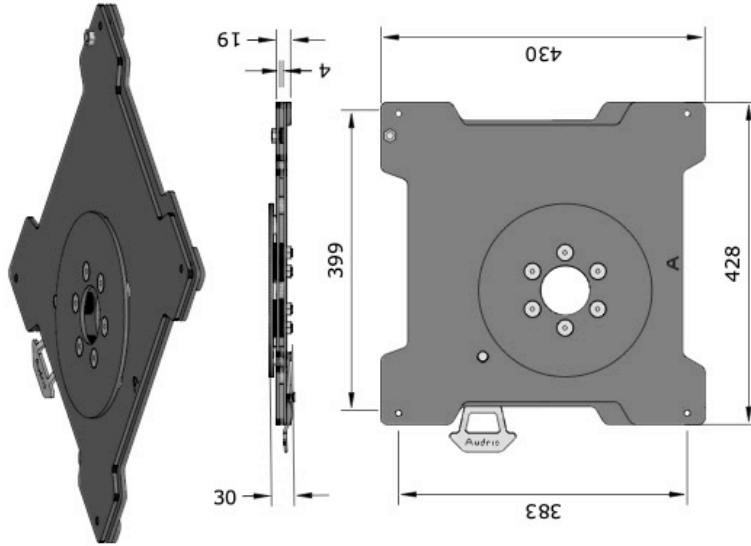

Driver's seat swivel

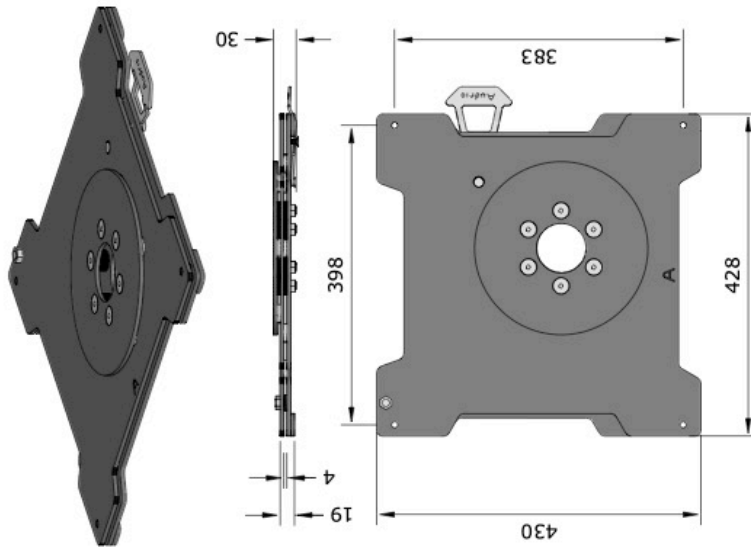

Audric SWIVELS	Drawn by A.Kručius	Date 10-Jan-26
		Sheet 1/4
Driver's and passenger swivel for VW T5-T6		

Passenger seat swivel

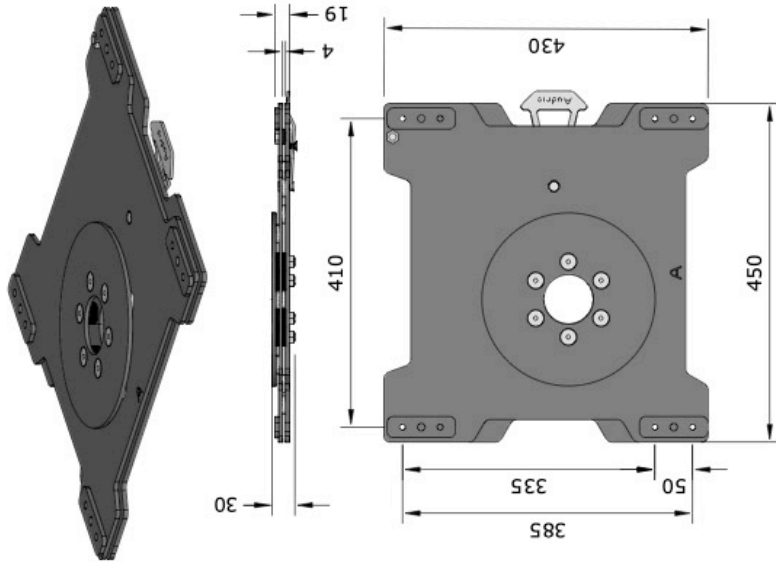

Driver's seat swivel

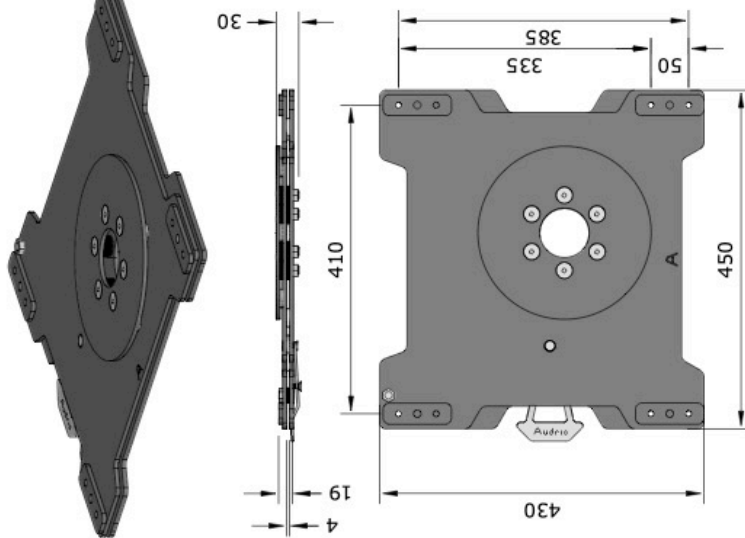

	Drawn by A. Krucius	Date 10-Jan-26
		Sheet 1/5
Driver's and passenger swivel for Fiat Ducato, Citroen Jumper, Peugeot Boxer		

		Date: 10.01.2026
	AUDRIOSWIVELS 01/2056-00	Page/pages: 16/16