

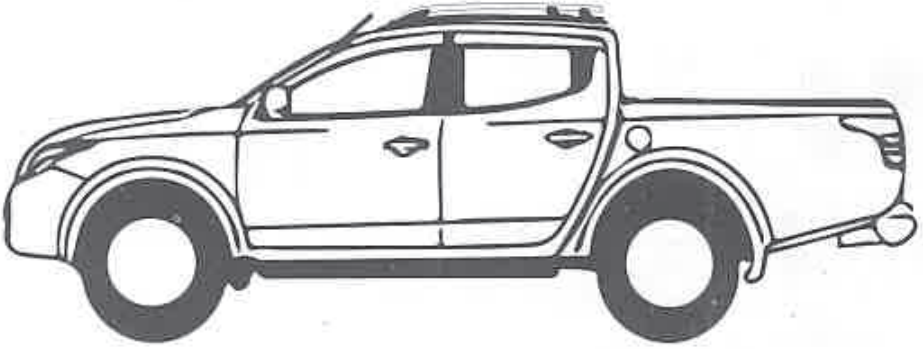

ONTEC
AUTO ACCESSORIES.CO



FIAT FULLBACK 2016> MITSUBISHI L200 2015>

(TR)	Montaj Talimatı :	PORT BAGAJ
(GB)	Fitting Instructions :	ROOF RACK
(D)	Montageanleitung :	DACHRELING
(F)	Instructions de Montage :	RIDELLES DE TOIT

(TR)

*Port bagaj taşıma kapasitesi 75 kg. olup; yükleme yapmadan önce aracın tavan taşıma kapasitesinin dikkate alınması gerekir.

(GB)

*Roof Rack carrying capacity is maximum 75 kg. Please check your vehicle roof maximum carrying capacity from your car manufacturer before load roof rack.

(G)

*Maximale Traglast unsere Dachrelinge betragen 75kg. Die freigegebenen Dachlasten der Fahrzeughersteller dürfen nicht überschritten werden. Bitte zur Kenntnisnahme!

(F)

*La capacité de chargement maximale est de 75 Kg. Nous vous prions de vérifier la capacité de chargement du toit de votre véhicule avant de charger les barres de toit.



30 Min.



PARÇA LİSTESİ

Part List / Teileliste / Lista de accesorios



- TR PLASTİK TAPA = 4 PARÇA
GB PLASTIC PLUG = 4 PIECES
D GUMMISTOPFEN = 4 STÜCK
F BOUCHON PLASTIQUE = 4 PIÈCES

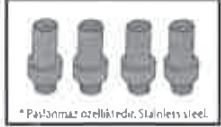





- TR BAĞLANTI APARATI = 4 PARÇA
GB CONNECTION BOLTS = 4 PIECES
D VERBINDUNGSBOLZEN = 4 STÜCK
F BOULONS DE RACCORDEMENT = 4 PIÈCES



- TR PUL = 4 PARÇA
GB RING WASHER = 4 PIECES
D UNTERLEGSCHIBE = 4 STÜCK
F RONDELLE AUTOBLOQUANTE = 4 PIÈCES



 = **Max. 75 kg**
Max. 165 lbs

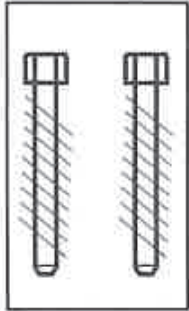
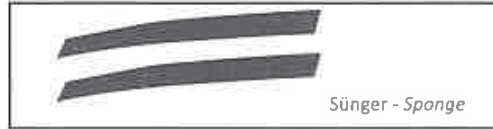

m-8 x 40 (FRONT 2 PIECES)

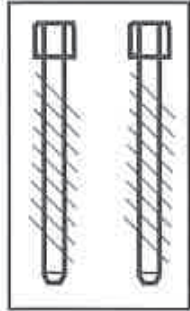

m-8 x 50 (MIDDLE 2 PIECES)



ALYAN ANAHTARI - HEX KEY

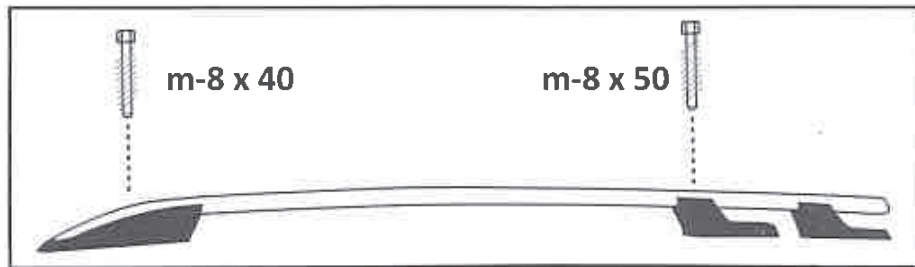

2

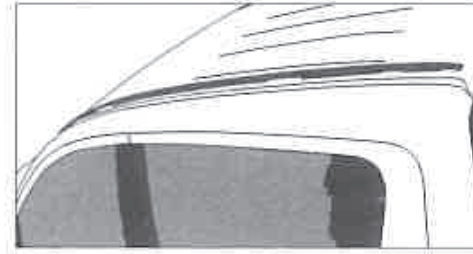

- 1) İlk olarak plastik fitilin sökülür.
1) Please remove the plastic trim.

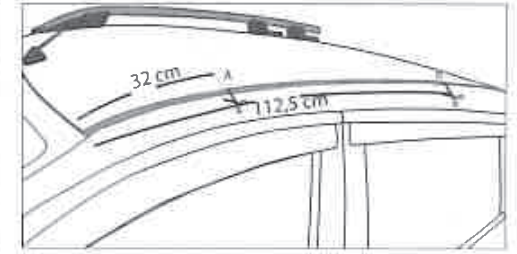

- 2) Ön fitil başlangıcından 32 cm ölçülüp 34, cm e kadar 2 cm lik fitil parçası kesilmelidir.Ön fitil başlangıcından 112,5 cm ölçülüp 114,5, cm e kadar 2 cm lik fitil parçası kesilmelidir.Bu kesilen parçalar fitil altındaki montaj noktasına ulaşmak içindir.
- 2) From the beginning of the front side of plastic trim. Please measure 32 cm to the back and cut 2 cm to the rear till the 34th cm to create a gap as 2 cm to make a way for the front connection bolt (Picture A). From the beginning of the plastic trim please measure 112,5 cm to the back and cut 2 cm to the rear till the 114,5 th cm to make way for the rear connection bolts (Picture B). Plastic trim should be placed again to the channel as it shown in the picture above. Please see the A and B points below.

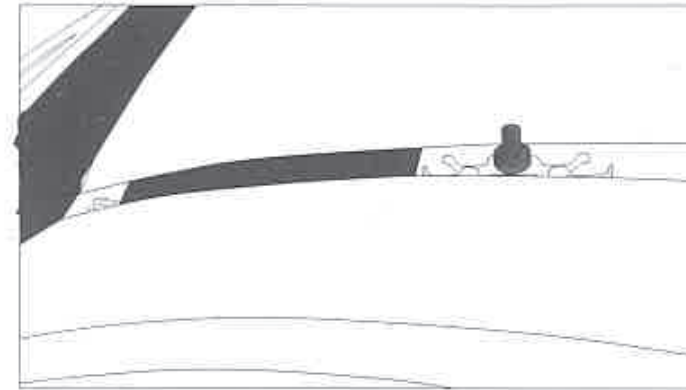
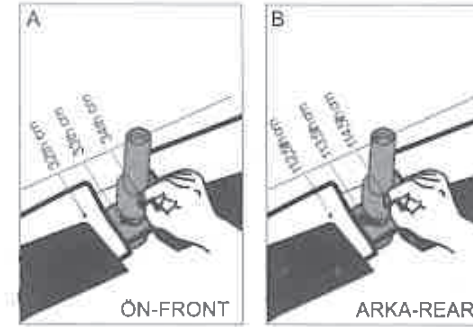

- 3) Kutu içerisindeki sünger besleme parçaları resimde gösterildiği gibi fitilin ön kısmının altına destek parçası şeklinde eklenir.
- 3) The support pieces that already exist in package put the under the wick which located by front side of car like shown via picture above.

3

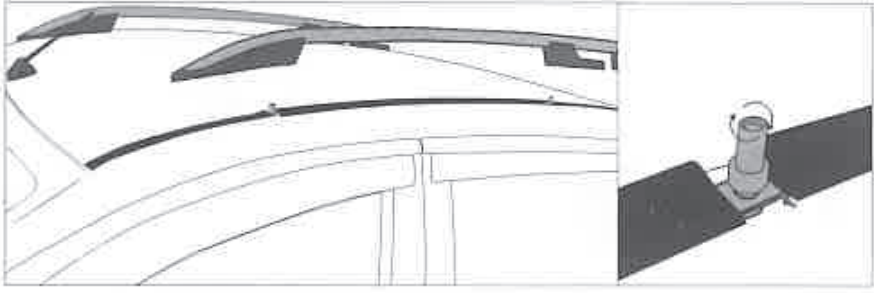

4) Bağlantı noktalarına bağlantı aparatları yerleştirilerek sıkılacaktır.

4) Please mount connection bolts to the connection points and tighten them.

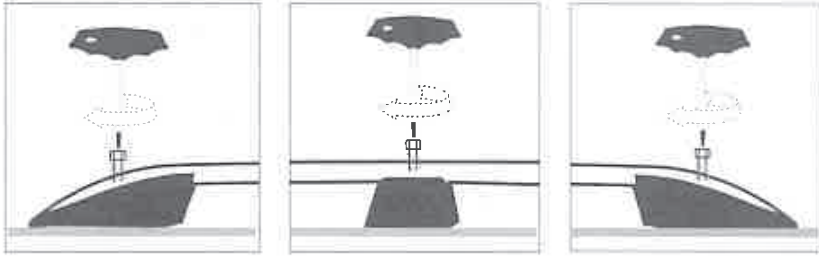

* Montajı yaparken ayakların vidalama işlemini sırayla tamamlamayınız. Vida ile sıkılması gereken noktaların hepsini önce orta derecede eşit şekilde, sonra sırayla sonuna kadar sıkınız.

* During the installation, Please do not screw the bolts in sequence in order to prevent overstress on the rack legs. Please screw all the bolts equally by a certain amount first and then finalize the process by screwing the all bolts completely.

* Ziehen Sie die Schrauben an den FüÙe während der Installation nicht einzeln an. Ziehen Sie alle Schrauben zuerst gleichmäßig an, dann nacheinander bis zum Ende.

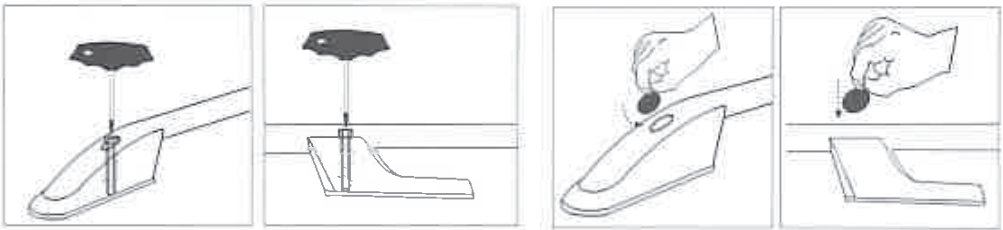

5) Portbagaj civataları bağlantı aparatlarına merkezlenerek üzerine oturtularak sıkılacaktır. Portbagaj tapalarını takarak montaj işlemi tamamlanır.

5) Please place the roof rail bolts centrally to connection holes and tighten them via hex key. By closing the holes upon roof rail via plastic caps, your roof rail will be ready to use!